

3-JAW CONCENTRIC GRIPPERS

INSTALLATION SIZE MGD812

1

Installation size MGD812 / 3-Jaw Concentric Grippers / pneumatic / Grippers

▶ PRODUCT SPECIFICATIONS



▶ Gripping force diagram

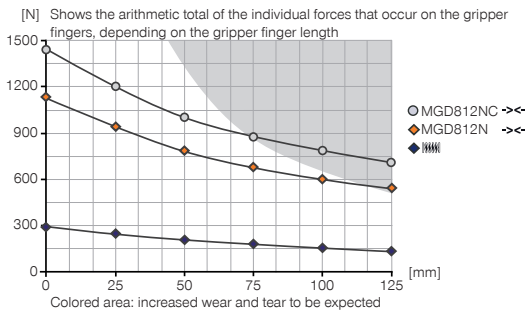

▶ Forces and moments

Displays static forces and moments that can also have an effect, besides the gripping force.

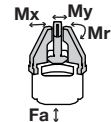

Mr [Nm]	41
Mx [Nm]	45
My [Nm]	65
Fa [N]	1500

▶ INCLUDED IN DELIVERY



Centering Disc

DST41000

▶ RECOMMENDED ACCESSORIES



Magnetic field sensor
Angled Cable 0,3 m -
Connector M8
MFS103SKHC



Magnetic field sensor
Straight Cable 0,3 m -
Connector M8
MFS204SKHC



Straight Fittings - Quick
Connect Style
GV1-8X6

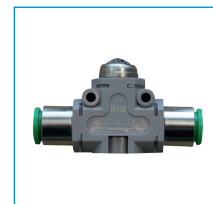

Quick Exhaust Valve
DEV06



Pressure Safety Valve
DSV1-8

Order no.	► Technical Data*	
	MGD812N	MGD812NC
Stroke per jaw [mm]	12	12
Gripping force in closing [N]	1130	1420
Gripping force in opening [N]	1200	
Gripping force secured by spring min. [N]		290
Closing time [s]	0.12	0.12
Opening time [s]	0.12	0.17
Repetition accuracy +/- [mm]	0.02	0.02
Operating pressure min. [bar]	3	4
Operating pressure max. [bar]	8	8
Operating temperature min. [°C]	5	5
Operating temperature max. [°C]	+80	+80
Air volume per cycle [cm³]	69	97
Weight [kg]	1.67	2

*All data measured at 6 bar

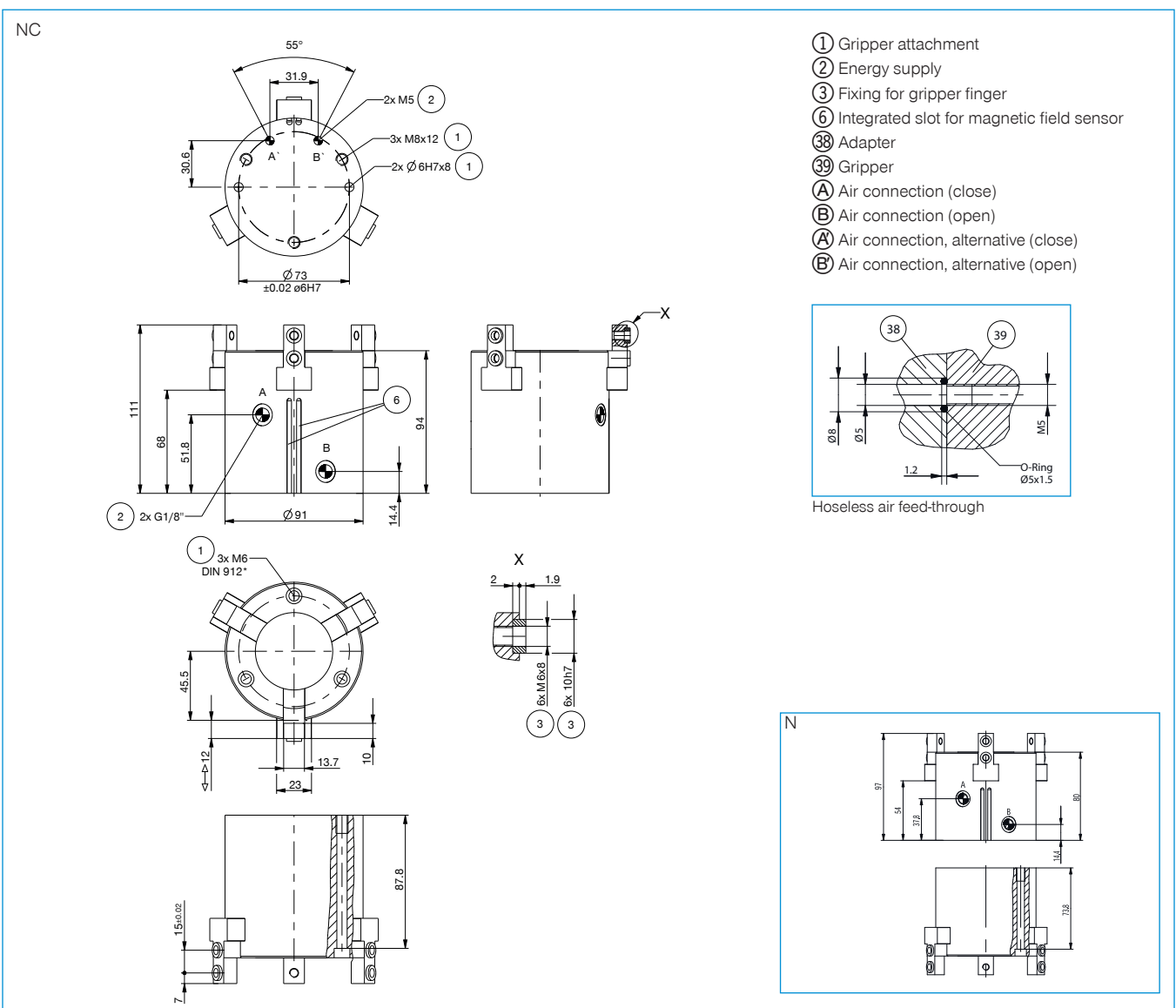

3-JAW CONCENTRIC GRIPPERS

SERIES MGD800

1

Series MGD800 / 3-Jaw Concentric Grippers / pneumatic / Grippers

▶ PRODUCT ADVANTAGES

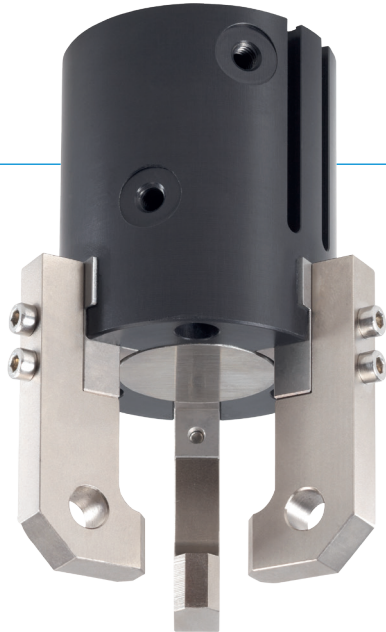

“The superior”

▶ **Gripper jaws may be almost 100% longer in comparison to the benchmark**

The highest force and torque measurement enables flexible for maximum dynamics

▶ **Best price/performance ratio**

Reduces your investment costs and speeds the ROI for your application

▶ **Failure-free continuous operation**

Our uncompromising „Made in Germany“ quality guarantees up to 10 million maintenance-free cycles

▶ THE BEST PRODUCT FOR YOUR APPLICATION

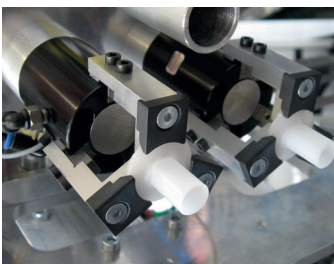

▶ **Our products welcome the challenge!**

Extreme conditions, all over the world—our tried and tested components and systems give you endless possibilities.

Find the best product for your specific use:

www.zimmer-group.de

HOW TO ORDER CORRECTLY

- ▶ The product order numbers are arranged according to this diagram:

Order no.	MGD803N	<input type="checkbox"/>		
For external gripping, self-locking, spring closing		C		



► BENEFITS IN DETAIL

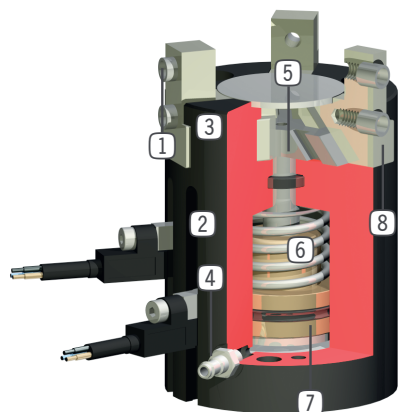

- ① **Removable centering sleeves**
 - quick and economical positioning of the gripper fingers
- ② **Sensing slot**
 - mounting and positioning of magnetic field sensors
- ③ **Robust, lightweight housing**
 - Hard-coated aluminum alloy
- ④ **Energy supply**
 - possible from several sides
- ⑤ **Wedge hook mechanism**
 - synchronized the movement of the gripper jaws
- ⑥ **Integrated gripping force safety device**
 - spring integrated into cylinder as energy storage (from size 803 upwards)
- ⑦ **Position sensing**
 - permanent magnet for direct monitoring of piston movement
- ⑧ **Precise T-Slot guide**
 - high forces and moments capacity

► SERIES CHARACTERISTICS



Number of installation sizes	8
Stroke per jaw	1 mm - 12 mm
Gripping force	30 N - 1420 N
Weight	0,025 kg - 2 kg
AP class	2



10 million maintenance-free cycles (max.)



Spring closing C



IP40



Magnetic field sensor