

2-JAW ANGULAR GRIPPERS

INSTALLATION SIZE GZ1040

1

Installation size GZ1040 / 2-Jaw Angular Grippers / pneumatic / Grippers

▶ PRODUCT SPECIFICATIONS



▶ Gripping force diagram

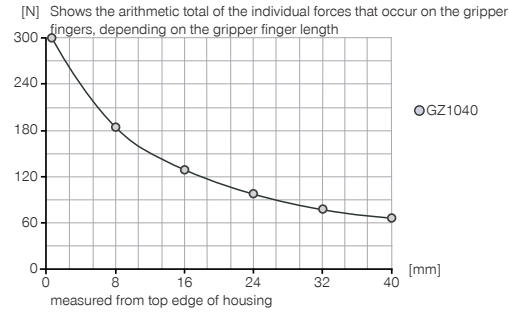

▶ Forces and moments

Displays static forces and moments that can also have an effect, besides the gripping force.

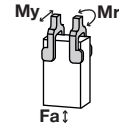

Mr [Nm]	2.5
My [Nm]	2
Fa [N]	200

▶ INCLUDED IN DELIVERY



Locking nut

C093620159

▶ RECOMMENDED ACCESSORIES

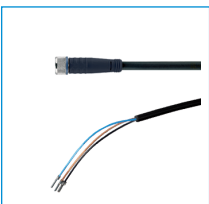

Plug-in connector Straight Cable 5m - Socket M8 (female)
KAG500



Straight Fittings - Quick Connect Style
GV1-8X6



Plug-in connector customizable Straight - Connector M8
S8-G-3



Plug-in connector customizable Straight - Connector M12
S12-G-3

Order no.	▶ Technical Data*		
	GZ1040-01	GZ1040-02	GZ1040-03
Stroke per jaw [°]	10	10	10
Gripping force in closing [N]	315	315	315
Closing moment [Nm]	4.4	4.4	4.4
Closing time [s]	0.02	0.02	0.02
Opening time [s]	0.04	0.04	0.04
Operating pressure min. [bar]	2	2	2
Operating pressure max. [bar]	6	6	6
Operating temperature min. [°C]	5	5	5
Operating temperature max. [°C]	+80	+80	+80
Air volume per cycle [cm ³]	2	2	2
Gripper finger with integrated sensor	No	Yes	No
Weight [kg]	0.11	0.125	0.105

*All data measured at 6 bar

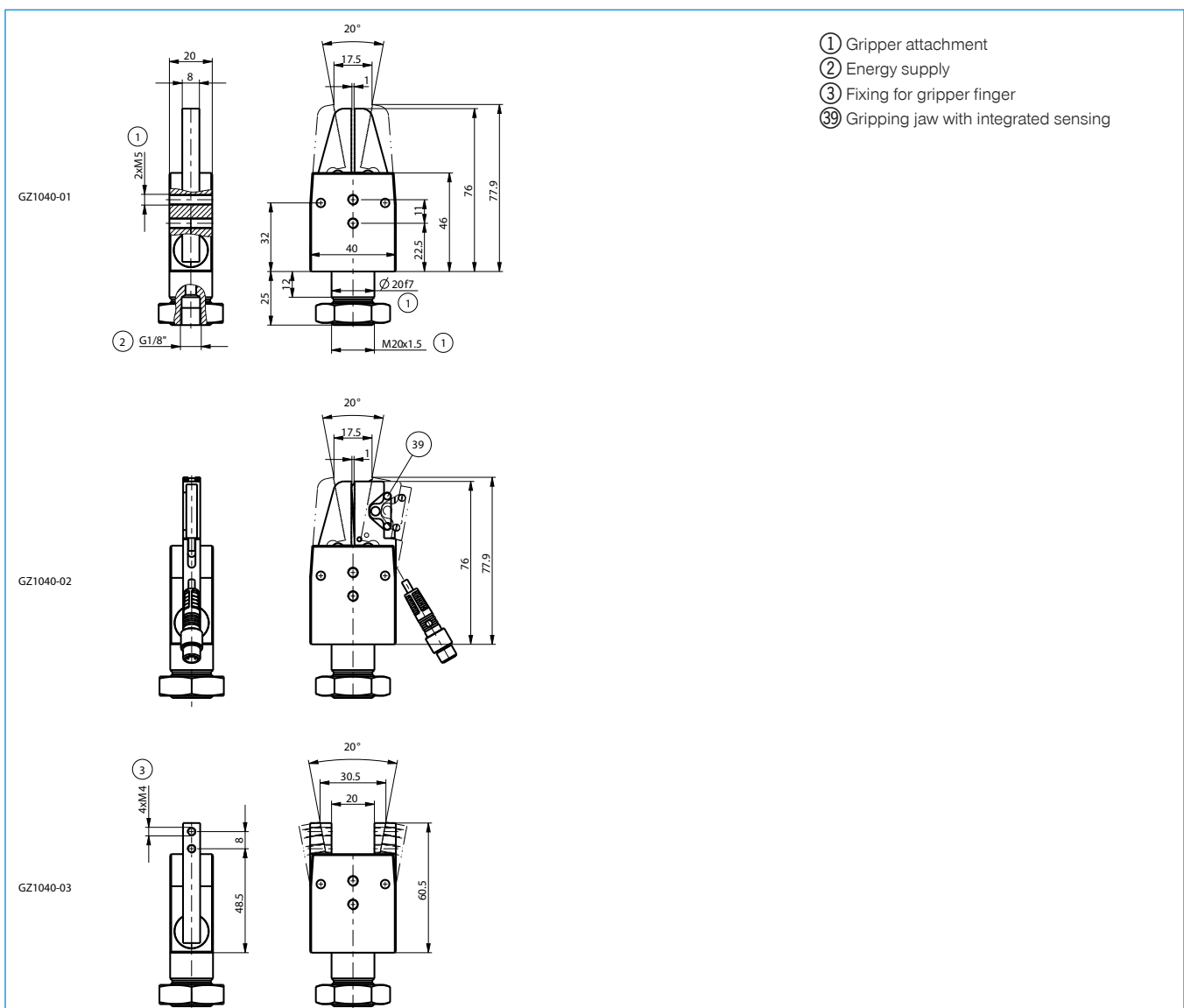

2-JAW ANGULAR GRIPPERS

SERIES GZ1000

1

Series GZ1000 / 2-Jaw Angular Grippers / pneumatic / Grippers

▶ PRODUCT ADVANTAGES



“The top of the line”

▶ Unique quality meets functionality

This is one of the best angular grippers on the market, enabling you to make your application more cost-effective and functional

▶ Variable attachment

Decide for yourself whether you want use screws, lock-nuts or a toolkit clamping system for fastening

▶ Sensing with process reliability

Unlike many other established products on the market, you can even differentiate between “Component present” and “Component not present”

▶ VERSIONS

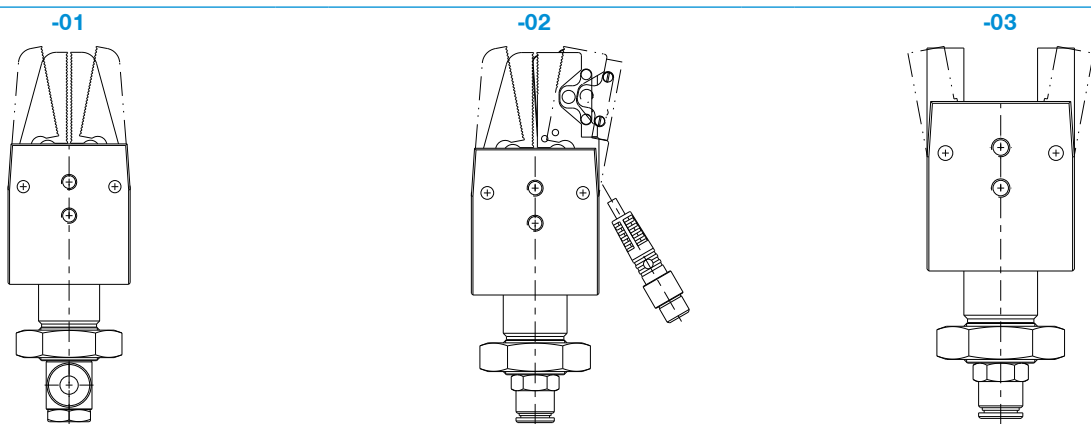

HOW TO ORDER CORRECTLY

▶ The product order numbers are arranged according to this diagram:

Order no.	GZ1030	<input type="checkbox"/>		
Saw tooth jaw without query		-01		
Saw tooth jaw with query		-02		
Version for attaching customer-specific gripper fingers		-03		



► BENEFITS IN DETAIL

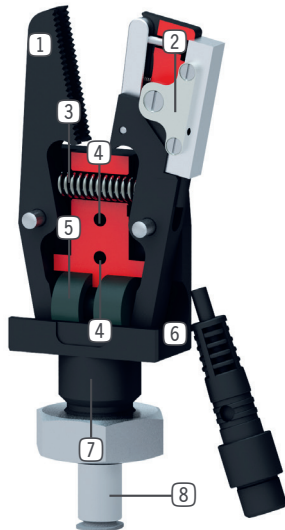

- ① **Gripper jaw**
- available in different versions
- ② **Position sensing**
- via inductive proximity switch
- ③ **Return spring**
- to open the gripper jaws
- ④ **Mounting and positioning**
- via thread / through-hole
- ⑤ **Drive**
- single-acting pneumatic cylinder
- ⑥ **Housing**
- hard coated surface for increased durability
- ⑦ **Mounting and positioning**
- via fit, thread and lock nut
- ⑧ **Energy supply**

► SERIES CHARACTERISTICS



Number of installation sizes	3
Stroke per jaw	8° - 10°
Gripping force	62 N - 315 N
Weight	0,015 kg - 0,125 kg
AP class	1



2 million maintenance-free cycles (max.)



Inductive sensor



IP30