

3-JAW CONCENTRIC GRIPPERS

INSTALLATION SIZE GD330

1

Installation size GD330 / 3-Jaw Concentric Grippers / pneumatic / Grippers

▶ PRODUCT SPECIFICATIONS

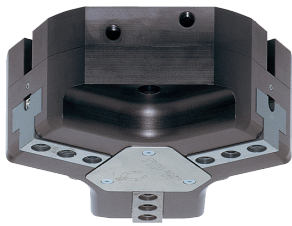

▶ Gripping force diagram

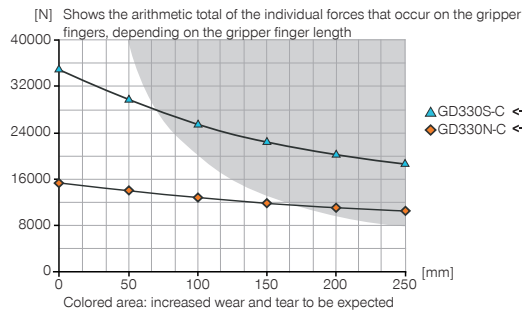

▶ Forces and moments

Displays static forces and moments that can also have an effect, besides the gripping force.

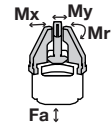

Mr [Nm]	200
Mx [Nm]	275
My [Nm]	300
Fa [N]	9000

▶ INCLUDED IN DELIVERY



Mounting block

KB8-34



Centering Disc

DST43000

▶ RECOMMENDED ACCESSORIES

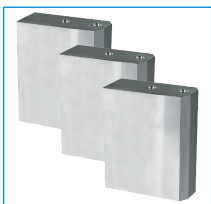

Universal Jaw Aluminium

UB330



Universal Jaw Steel

UB330ST



Alternate proximity bracket

KHA330-B-8



Inductive proximity switch - Connector M8

NJ8-E2S



Magnetic field sensor Angled Cable 0,3 m - Connector M8

MFS103SKHC



Magnetic field sensor Straight Cable 0,3 m - Connector M8

MFS204SKHC

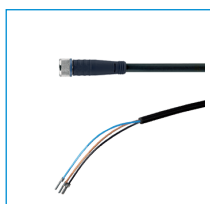

Plug-in connector Straight Cable 5m - Socket M8 (female)

KAG500



Straight Fittings - Quick Connect Style

GV1-4X8



Angled Fittings - Quick Connect Style

WV1-4X8



Pressure Safety Valve

DSV1-8

Order no.	▶ Technical Data*	
	GD330N-C	GD330S-C
Stroke per jaw [mm]	30	15
Gripping force in closing [N]	15300	34150
Gripping force in opening [N]	15550	34700
Gripping force secured by spring min. [N]		
Closing time [s]	0.8	0.8
Opening time [s]	0.8	0.8
Repetition accuracy +/- [mm]	0.05	0.05
Operating pressure min. [bar]	2	2
Operating pressure max. [bar]	8	8
Operating temperature min. [°C]	5	5
Operating temperature max. [°C]	+80	+80
Air volume per cycle [cm³]	2270	2270
Weight [kg]	24	24

*All data measured at 6 bar

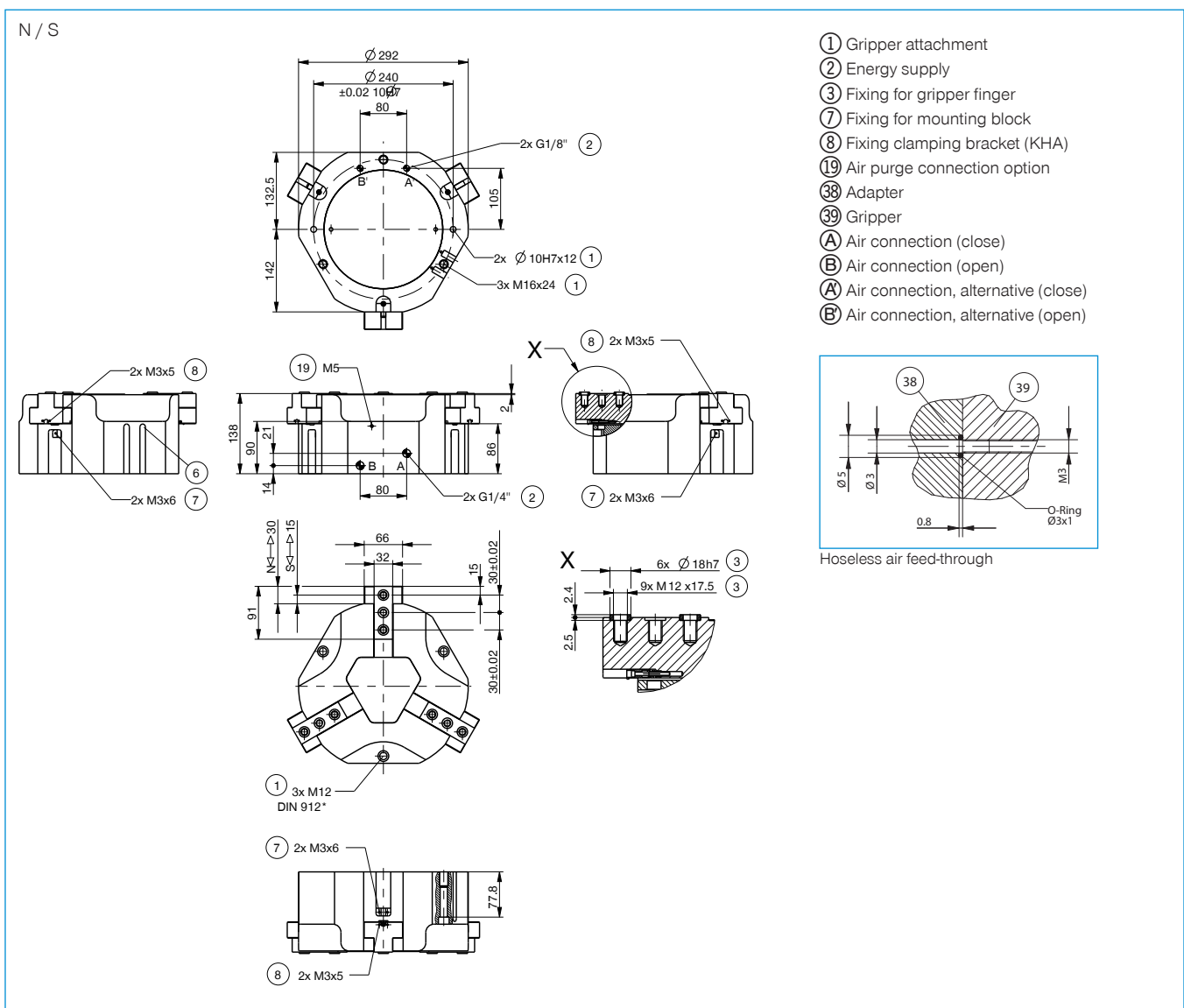

3-JAW CONCENTRIC GRIPPERS

SERIES GD300

1

Series GD300 / 3-Jaw Concentric Grippers / pneumatic / Grippers

▶ PRODUCT ADVANTAGES



“The economical”

▶ Concentration on the essentials

The most economic type of gripping: This is how you reduce your production costs

▶ Proven T slot guide

This established and proven guiding technology stands for the highest process reliability like no other

▶ Compact structure

Reduces the interference contours for your application

▶ THE BEST PRODUCT FOR YOUR APPLICATION

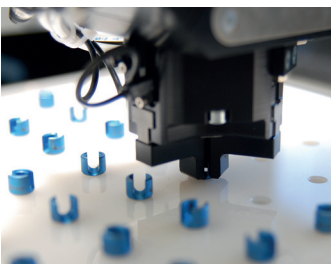

▶ Our products welcome the challenge!

Extreme conditions, all over the world—our tried and tested components and systems give you endless possibilities.

Find the best product for your specific use:

www.zimmer-group.de

HOW TO ORDER CORRECTLY

▶ The product order numbers are arranged according to this diagram:

Order no.	GD304	<input type="checkbox"/>	<input type="checkbox"/>	-C
Long stroke		N		
High force		S		
For external gripping, self-locking, spring closing			C	
For internal gripping, self-locking, spring opening			O	



► BENEFITS IN DETAIL

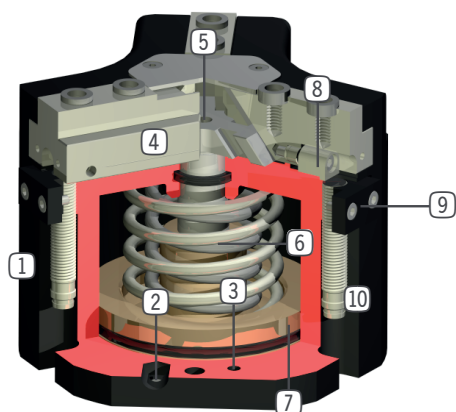

- ① **Robust, lightweight housing**
- Hard-coated aluminum alloy
- ② **Energy supply**
- possible from several sides
- ③ **Mounting and positioning**
- mounting possible from several sides for versatile positioning
- ④ **Gripper jaw**
- individual gripper finger mounting
- ⑤ **Wedge hook mechanism**
- synchronized the movement of the gripper jaws
- high force transfer
- ⑥ **Integrated gripping force safety device**
- spring integrated into cylinder as energy storage
- ⑦ **Position sensing**
- permanent magnet for direct monitoring of piston movement
- ⑧ **Integrated, adjustable switch cam**
- for direct position sensing of the gripper jaw
- ⑨ **Mounting block**
- mounting for inductive proximity switch (10)

► SERIES CHARACTERISTICS



Number of installation sizes	9
Stroke per jaw	3 mm - 30 mm
Gripping force	200 N - 34700 N
Weight	0,13 kg - 24 kg
AP class	3



10 million maintenance-free cycles (max.)



High-strength S



Magnetic field sensor



Spring closing C



Inductive sensor



Purged air



Spring opening O



IP40