

2-JAW PARALLEL GRIPPERS

INSTALLATION SIZE MGP810

1

▶ PRODUCT SPECIFICATIONS



▶ Gripping force diagram

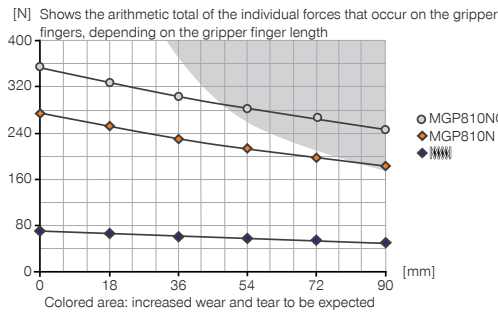

▶ Forces and moments

Displays static forces and moments that can also have an effect, besides the gripping force.

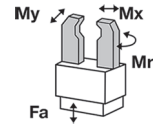

Mr [Nm]	9
Mx [Nm]	32
My [Nm]	12
Fa [N]	590

▶ INCLUDED IN DELIVERY



Centering Disc

DST07540

▶ RECOMMENDED ACCESSORIES



Magnetic field sensor
Angled Cable 0,3 m -
Connector M8
MFS103SKHC



Magnetic field sensor
Straight Cable 0,3 m -
Connector M8
MFS204SKHC

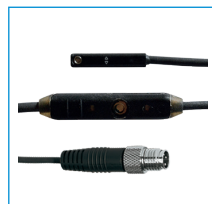

2-Position-Sensor Cable
0,3 m - Connector M8
MFSP2SKHC-02

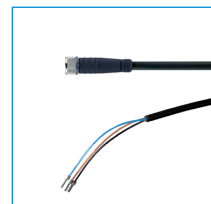

Plug-in connector Straight
Cable 5m - Socket M8
(female)
KAG500



Straight Fittings - Quick
Connect Style
GVM5



Angled Fittings - Quick
Connect Style
WVM5



Quick Exhaust Valve
DEV04

Order no.	► Technical Data*	
	MGP810N	MGP810NC
Stroke per jaw [mm]	10	10
Gripping force in closing [N]	270	350
Gripping force in opening [N]	310	
Gripping force secured by spring min. [N]		80
Closing time [s]	0.04	0.04
Opening time [s]	0.04	0.06
Repetition accuracy +/- [mm]	0.02	0.02
Operating pressure min. [bar]	3	4
Operating pressure max. [bar]	8	8
Operating temperature min. [°C]	5	5
Operating temperature max. [°C]	+80	+80
Air volume per cycle [cm ³]	15.2	20.5
Weight [kg]	0.28	0.32

*All data measured at 6 bar

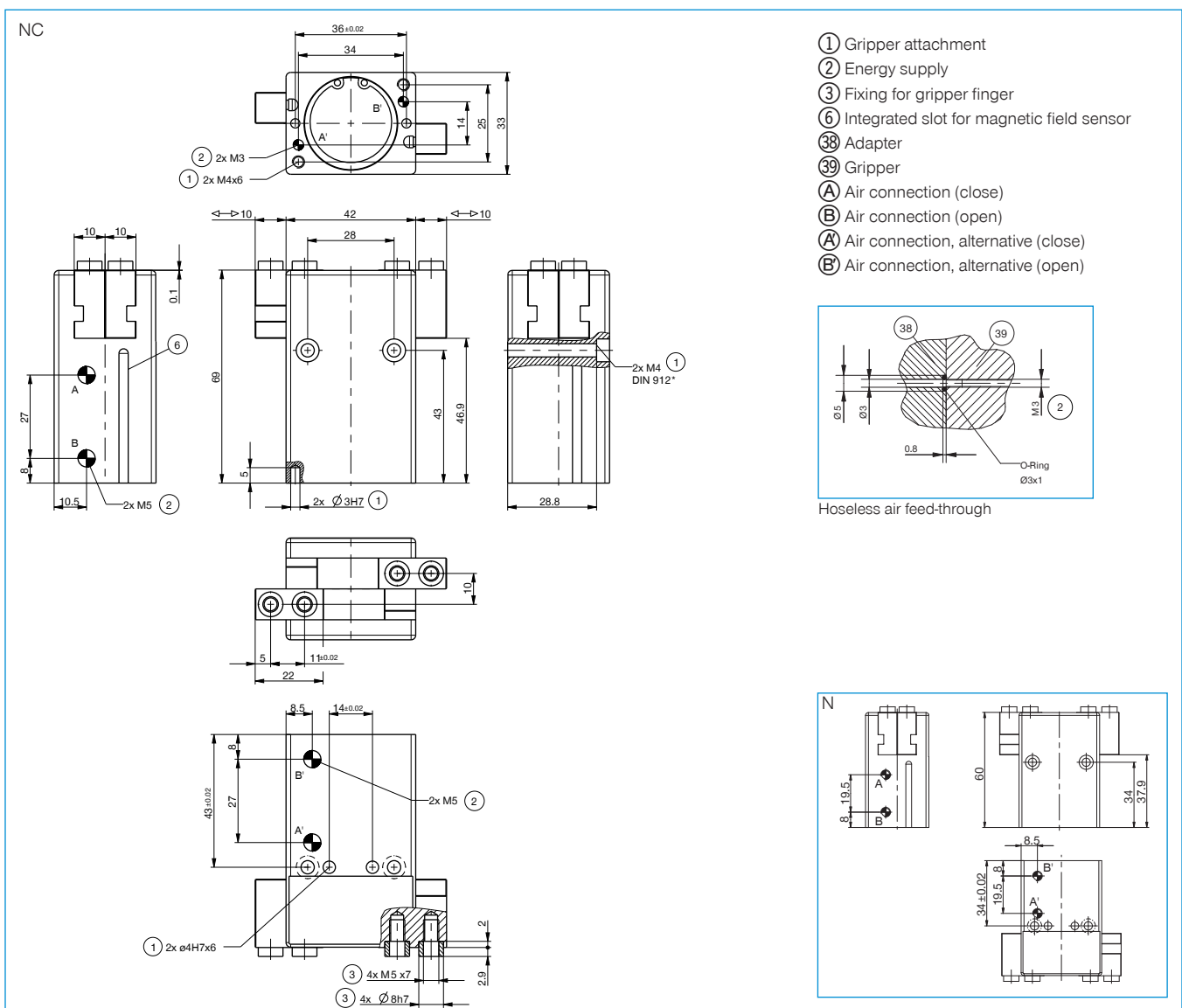

2-JAW PARALLEL GRIPPERS

SERIES MGP800

1

Series MGP800 / 2-Jaw Parallel Grippers / pneumatic / Grippers

▶ PRODUCT ADVANTAGES

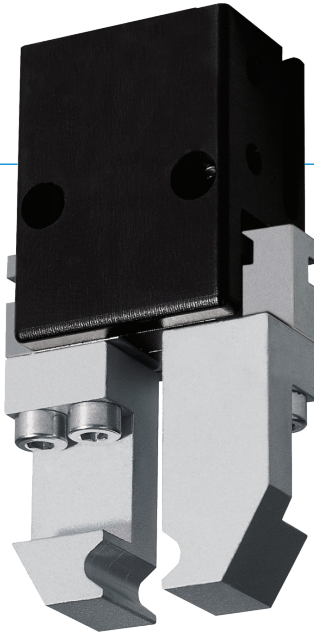

“The powerful”

- ▶ **Over 40% more powerful than the benchmark**
Optimisation of weight and force reduces your application costs since all components can have a smaller scale
- ▶ **Gripper jaws up to 50% longer than the benchmark**
The highest force and torque measurement enables flexible use for maximum dynamics
- ▶ **Failure-free continuous operation**
Our uncompromising „Made in Germany“ quality guarantees up to 10 million maintenance-free cycles

▶ THE BEST PRODUCT FOR YOUR APPLICATION



- ▶ **Our products welcome the challenge!**
Extreme conditions, all over the world—our tried and tested components and systems give you endless possibilities.
Find the best product for your specific use:
www.zimmer-group.de

HOW TO ORDER CORRECTLY

- ▶ The product order numbers are arranged according to this diagram:

Order no.	MGP803N	<input type="checkbox"/>		
For external gripping, self-locking, spring closing		C		



BENEFITS IN DETAIL

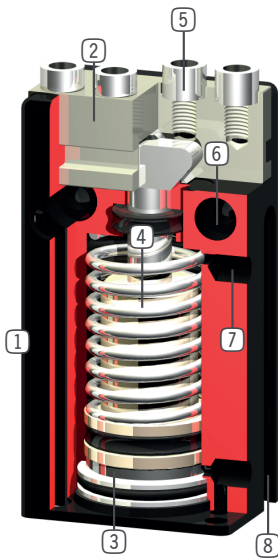

- ① **Robust, lightweight housing**
- Hard-coated aluminum alloy
- ② **Gripper jaw**
- individual gripper finger mounting
- ③ **Position sensing**
- permanent magnet for direct monitoring of piston movement
- ④ **Integrated gripping force safety device**
- spring integrated into cylinder as energy storage (from size 803 upwards)
- ⑤ **Removable centering sleeves**
- quick and economical positioning of the gripper fingers
- ⑥ **Mounting and positioning**
- mounting possible from several sides for versatile positioning
- ⑦ **Energy supply**
- possible from several sides
- ⑧ **Sensing slot**
- mounting and positioning of magnetic field sensors

SERIES CHARACTERISTICS



Number of installation sizes	8
Stroke per jaw	1 mm - 12 mm
Gripping force	6 N - 400 N
Weight	0,008 kg - 0,46 kg
AP class	2



10 million maintenance-free cycles (max.)



Spring closing C



IP40



Magnetic field sensor