

2-JAW PARALLEL GRIPPERS WITH LONG STROKE INSTALLATION SIZE MGH8230

1

Installation size MGH8230 / 2-Jaw Parallel Grippers with Long Stroke / pneumatic / Grippers

▶ PRODUCT SPECIFICATIONS



▶ Gripping force diagram

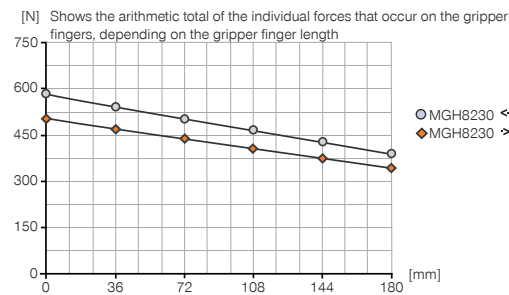

▶ Forces and moments

Displays static forces and moments that can also have an effect, besides the gripping force.

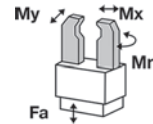

Mr [Nm]	64
Mx [Nm]	64
My [Nm]	45
Fa [N]	760

▶ INCLUDED IN DELIVERY



Centering Disc

DST41000

▶ RECOMMENDED ACCESSORIES



Attachment Kit for Inductive Proximity Switch

ANS0022



Inductive proximity switch - Cable 5 m

NJ8-E2



Inductive proximity switch - Connector M8

NJ8-E2S



Magnetic field sensor Angled Cable 5 m

MFS103KHC



Magnetic field sensor Angled Cable 0,3 m - Connector M8

MFS103SKHC



Magnetic field sensor Straight Cable 5 m

MFS204KHC



Magnetic field sensor Straight Cable 0,3 m - Connector M8

MFS204SKHC



Plug-in connector Straight Cable 5m - Socket M8 (female)

KAG500

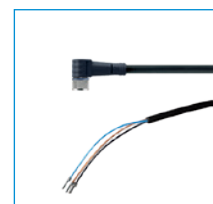

Plug-in connector Angled Cable 5m - Socket M8 (female)

KAW500



Straight Fittings - Quick Connect Style

GVM5

► Technical Data*	
Order no.	MGH8230
Stroke per jaw [mm]	30
Gripping force in closing [N]	500
Gripping force in opening [N]	570
Closing time [s]	0.14
Opening time [s]	0.1
Repetition accuracy +/- [mm]	0.05
Operating pressure min. [bar]	3
Operating pressure max. [bar]	8
Operating temperature min. [°C]	5
Operating temperature max. [°C]	+80
Air volume per cycle [cm ³]	64
Weight [kg]	2.4

*All data measured at 6 bar

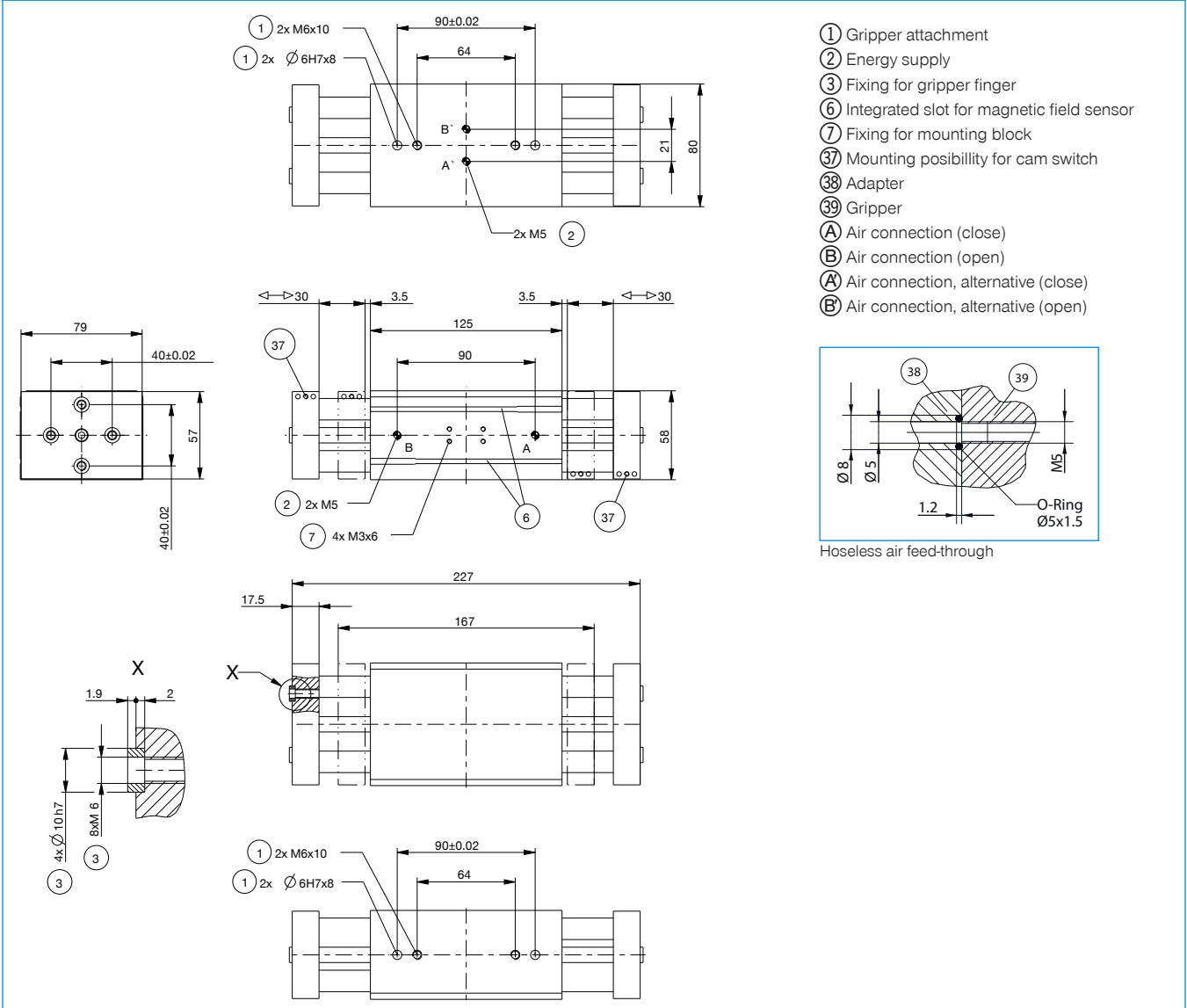

2-JAW PARALLEL GRIPPERS WITH LONG STROKE SERIES MGH8000

1

▶ PRODUCT ADVANTAGES

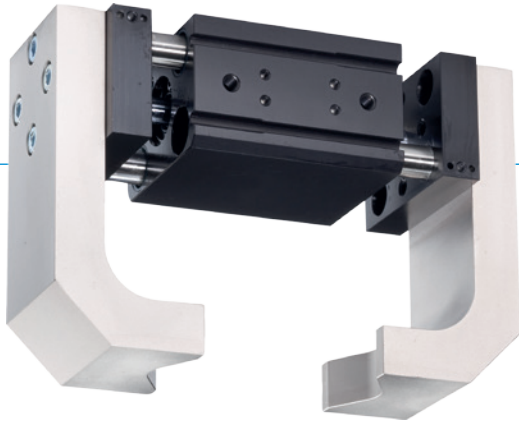

“The compact”

▶ Reduced interference contours

Low-profile designs and versatile screw connection options enable simple integration into your design

▶ Dirt protection

Using the scrapers on the guides, you can reliably use the gripper even under the harshest conditions

▶ Failure-free continuous operation

Our uncompromising „Made in Germany“ quality guarantees up to 10 million maintenance-free cycles

▶ THE BEST PRODUCT FOR YOUR APPLICATION



▶ Our products welcome the challenge!

Extreme conditions, all over the world—our tried and tested components and systems give you endless possibilities.

Find the best product for your specific use:

www.zimmer-group.de



► BENEFITS IN DETAIL

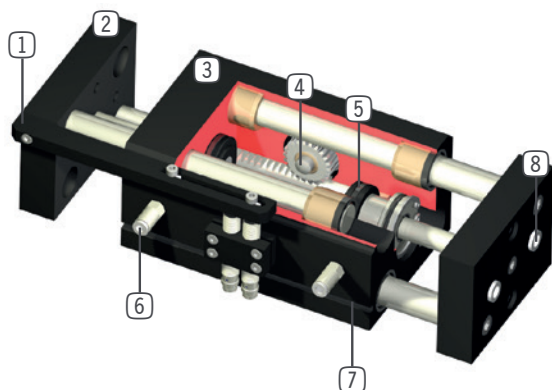

- ① **Attachment kit (cam switch and clamping block)**
 - for sensing position by means of proximity switch (optional feature)
- ② **Gripper jaw**
 - individual gripper finger mounting
- ③ **Robust, lightweight housing**
 - Hard-coated aluminum alloy
- ④ **Synchronization**
 - via rack and pinion
- ⑤ **Drive**
 - two double-acting pneumatic cylinders
- ⑥ **Energy supply**
 - possible from several sides
- ⑦ **Integrated groove**
 - mounting and positioning of magnetic field sensors
- ⑧ **Removable centering sleeves**
 - quick and economical positioning of the gripper fingers

► SERIES CHARACTERISTICS



Number of installation sizes	3
Stroke per jaw	10 mm - 100 mm
Gripping force	60 N - 910 N
Weight	0,35 kg - 7,3 kg
AP class	2



10 million maintenance-free cycles (max.)



Inductive sensor



IP64



Magnetic field sensor