

▶ PRODUCT SPECIFICATIONS

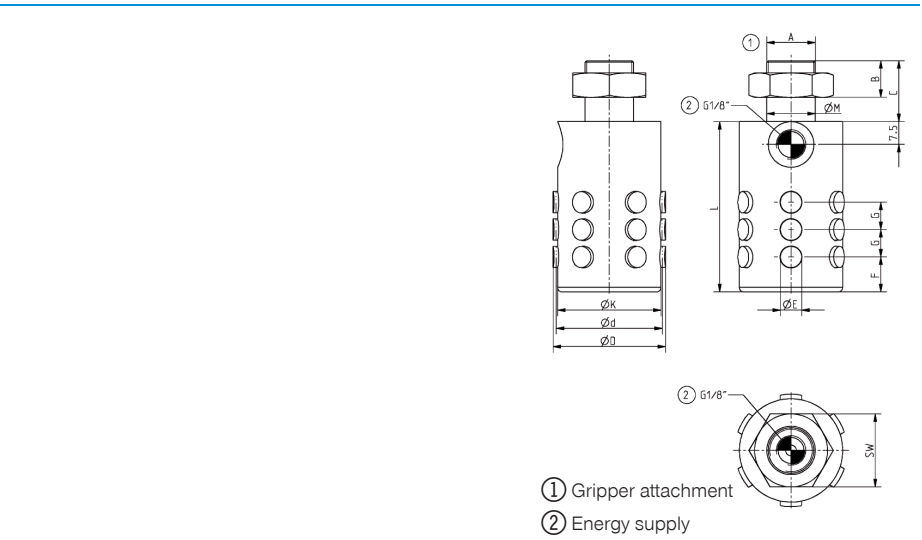

▶ RECOMMENDED ACCESSORIES



Straight Fittings - Quick Connect Style
GV1-8X6



Quick Exhaust Valve
DEV06

Order no.	▶ Technical Data*									
	LG35-39	LG40-45	LG46-51	LG51-56	LG56-62	LG63-70	LG71-80	LG76-84	LG81-90	LG91-100
Total stroke in Ø [mm]	4.5	6.5	6	7	7.5	8	10.5	8.5	11	10
Clamping diameter d min. [mm]	34.5	39.5	45.5	50.5	55.5	62.5	70.5	75.5	80.5	90.5
Clamping diameter D max. [mm]	39	46	51.5	57.5	63	70.5	81	84	91.5	100.5
Gripping force in extraction [N]	300	400	500	750	900	1100	1500	1700	2000	2500
Retract time / Extend time [s]	0.2	0.3	0.3	0.3	0.3	0.3	0.3	0.3	0.4	0.4
Repetition accuracy +/- [mm]	0.05	0.05	0.05	0.05	0.05	0.05	0.05	0.05	0.05	0.05
Operating pressure min. [bar]	2	2	2	2	2	2	2	2	2	2
Operating pressure max. [bar]	6	6	6	6	6	6	6	6	6	6
Air volume per cycle [cm³]	5	8	13	17	25	33	42	53	67	117
Operating temperature min. [°C]	5	5	5	5	5	5	5	5	5	5
Operating temperature max. [°C]	+80	+80	+80	+80	+80	+80	+80	+80	+80	+80
A	M16X1	M16X1	M16X1	M16X1	M16X1	M20X1.5	M20X1.5	M20X1.5	M20X1.5	M20X1.5
B [mm]	12	12	12	12	12	15	15	15	15	15
C [mm]	20	20	20	20	20	25	25	25	25	25
E Ø [mm]	7	8	9	10	11	12.5	15	15.5	16	18
F [mm]	11.5	14	15.5	17	19	21.5	21.5	22.7	24.5	26.5
G [mm]	9	11	12	13	14.5	15.5	18	19	20	22.5
K Ø [mm]	34	39	45	50	50	62	70	75	80	90
L [mm]	56	62	68	74	80	86	92	96	100	110
M Ø [mm]	16h7	16h7	16h7	16h7	16h7	20h7	20h7	20h7	20h7	20h7
Weight [kg]	0.13	0.178	0.26	0.37	0.373	0.53	0.69	0.8	1	1.3

*All data measured at 6 bar

INTERNAL GRIPPER SERIES LGG

1

Series LGG / Internal gripper / pneumatic / Grippers

▶ PRODUCT ADVANTAGES



▶ **Surface protection with rubber knobs**

Continuously protect the surface of your workpieces and minimise rejections in the process

▶ **Secure hold**

The coefficient of friction ensures your workpiece stays held reliably, even under high dynamics

▶ **Direct drive**

The control system with only one pneumatic line reduces installation effort and interference contours

▶ THE BEST PRODUCT FOR YOUR APPLICATION

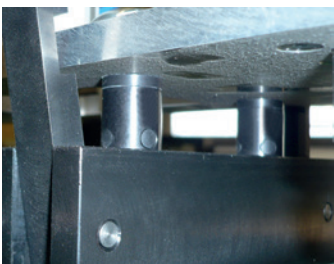

▶ **Our products welcome the challenge!**

Extreme conditions, all over the world—our tried and tested components and systems give you endless possibilities.

Find the best product for your specific use:

www.zimmer-group.de



► BENEFITS IN DETAIL

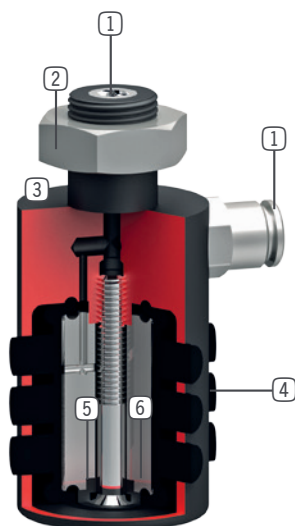

- ① **Energy supply**
 - radial
 - axial and radial from LG35-39
- ② **Fixing**
 - by fit, thread and locknut
- ③ **Robust, lightweight housing**
 - Hard-coated aluminum alloy
 - no overstretching of the rubber membrane at empty stroke
- ④ **Direct gripping with rubber knobs**
 - high retention force due to good friction value, approx. 0.5 with rubber
- ⑤ **Gripping with single-acting rubber membranes**
 - low actuate effort
 - reset when venting
 - adjustable force with operating pressure (2 - 6 bar)
- ⑥ **Inner core**
 - saves air volume and cycle time (from LG35-39)

► FURTHER INFORMATION IS AVAILABLE ONLINE



► Technical Information

All information just a click away at: www.zimmer-group.com

Find data, illustrations, 3D models and operating instructions for your installation size using the order number for your desired product.

Quick, clear and always up-to-date.

