

MAGNETIC GRIPPER

INSTALLATION SIZE HM1046

1

▶ PRODUCT SPECIFICATIONS



▶ RECOMMENDED ACCESSORIES

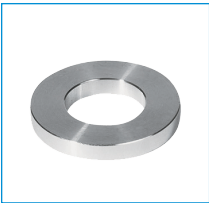

Centering Disc

ZE10H7X6



Ball Joints

KG40



Ball Joints Steel

KG40ST



Straight Fittings - Quick Connect Style

GVM5

Order no.	Technical Data
Adhesive force max. [N]	65
Operating pressure min. [bar]	3
Operating pressure max. [bar]	8
Operating temperature min. [°C]	5
Operating temperature max. [°C]	+80
Air volume per cycle [cm ³]	9
Weight [kg]	0.28

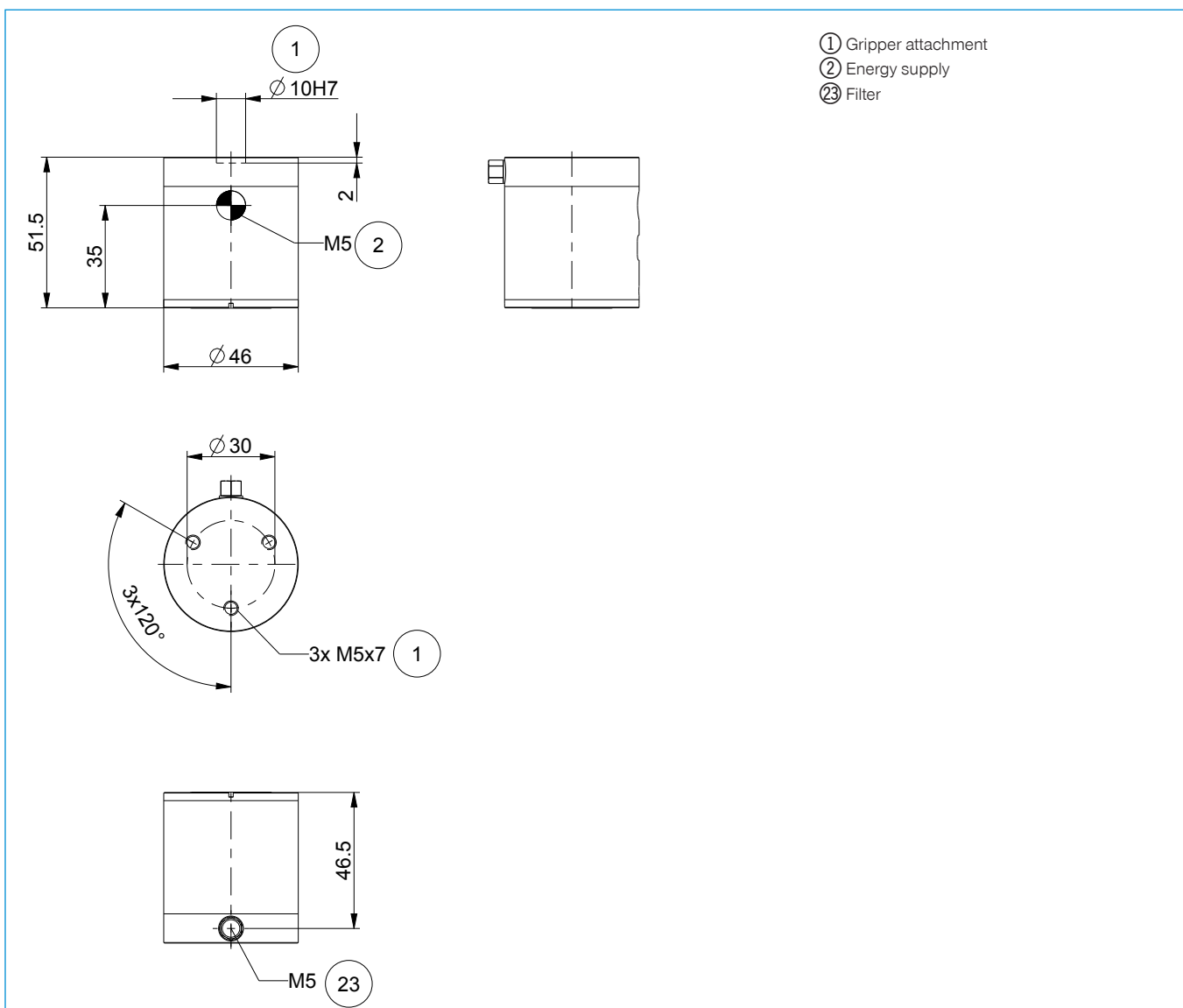

MAGNETIC GRIPPER

SERIES HM1000

1

▶ PRODUCT ADVANTAGES



▶ **Secure hold during EMERGENCY STOP**

Magnets attached to springs ensure your workpiece remains secure, even during a drop in pressure

▶ **Contact plate that increases friction value**

The replaceable O-ring ensures the high dynamics in your application and protection of your workpiece

▶ **Residual holding force < 1N**

The demagnetised contact surface safeguards the process reliability of dropping off your workpiece

▶ THE BEST PRODUCT FOR YOUR APPLICATION



▶ **Our products welcome the challenge!**

Extreme conditions, all over the world—our tried and tested components and systems give you endless possibilities.

Find the best product for your specific use:

www.zimmer-group.de



► BENEFITS IN DETAIL

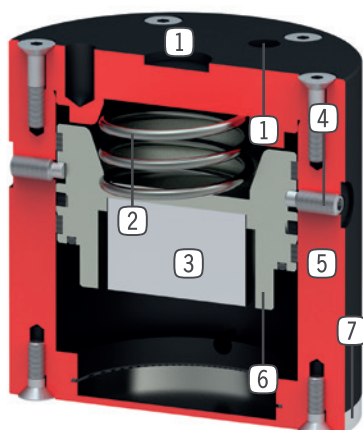

- ① **Mounting and positioning**
 - via centering sleeve and thread
- ② **Spring**
 - for piston return
 - secured holding even in drop pressure
- ③ **Permanent magnet**
 - requires no power supply
 - high holding forces
- ④ **Transport safeguarding**
- ⑤ **Robust, lightweight housing**
 - Hard-coated aluminum alloy
- ⑥ **single-acting pneumatic cylinders**
 - only one pneumatic line required
 - Spring return
- ⑦ **Contact plate**
 - easy replaceable
 - embedded O-ring to increase the friction coefficient

► FURTHER INFORMATION IS AVAILABLE ONLINE



► Technical Information

All information just a click away at: www.zimmer-group.com

Find data, illustrations, 3D models and operating instructions for your installation size using the order number for your desired product.

Quick, clear and always up-to-date.

