

3-JAW CONCENTRIC GRIPPERS

INSTALLATION SIZE GPD5013

PRODUCT SPECIFICATIONS

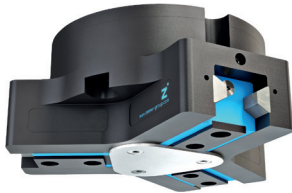

Gripping force diagram

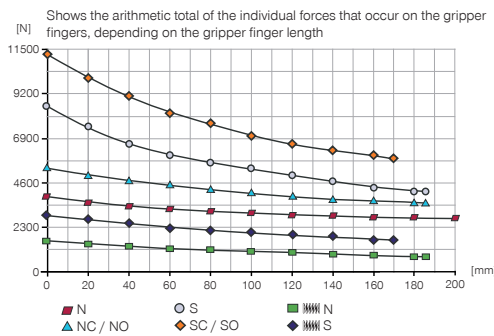

Forces and moments

Displays static forces and moments that can also have an effect, besides the gripping force.

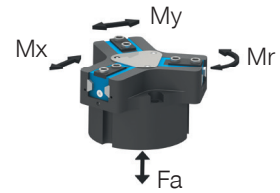

Mr [Nm]	110
Mx [Nm]	150
My [Nm]	130
Fa [N]	3300

TECHNICAL DATA

Order no.	Technical data					
	GPD5013N-00-A	GPD5013NC-00-A	GPD5013NO-00-A	GPD5013S-00-A	GPD5013SC-00-A	GPD5013SO-00-A
Stroke per jaw [mm]	13	13	13	6	6	6
Gripping force in closing [N]	3770	5060		8310	11160	
Gripping force in opening [N]	3910		5200	8600		11450
Gripping force secured by spring min. [N]		1290	1290		2850	2850
Closing time [s]	0.19	0.15	0.25	0.19	0.15	0.25
Opening time [s]	0.19	0.25	0.15	0.19	0.25	0.15
Permissible weight per jaw max [kg]	2.4	2.4	2.4	2.4	2.4	2.4
Length of the gripper fingers max. [mm]	200	185	185	185	170	170
Repetition accuracy +/- [mm]	0.01	0.01	0.01	0.01	0.01	0.01
Operating pressure min. [bar]	3	4	4	3	4	4
Operating pressure max. [bar]	8	7	7	8	7	7
Nominal operating pressure [bar]	6	6	6	6	6	6
Operating temperature [°C]	-10 ... +90	-10 ... +90	-10 ... +90	-10 ... +90	-10 ... +90	-10 ... +90
Air volume per cycle [cm³]	230	415	415	230	415	415
Protection to IEC 60529	IP64	IP64	IP64	IP64	IP64	IP64
Weight [kg]	2.6	3.7	3.7	2.6	3.7	3.7

Order no.	Technical Data - High Temperature Version					
	GPD5013N-20-A	GPD5013NC-20-A	GPD5013NO-20-A	GPD5013S-20-A	GPD5013SC-20-A	GPD5013SO-20-A
Operating temperature [°C]	-10 ... +130	-10 ... +130	-10 ... +130	-10 ... +130	-10 ... +130	-10 ... +130

Order no.	Technical Data - Protector Version					
	GPD5013N-21-A	GPD5013NC-21-A	GPD5013NO-21-A	GPD5013S-21-A	GPD5013SC-21-A	GPD5013SO-21-A
Protection to IEC 60529	IP67 *	IP67 *	IP67 *	IP67 *	IP67 *	IP67 *
Weight [kg]	3.15	4.3	4.3	3.15	4.3	4.3

Order no.	Technical Data - High Temperature Protector Version					
	GPD5013N-24-A	GPD5013NC-24-A	GPD5013NO-24-A	GPD5013S-24-A	GPD5013SC-24-A	GPD5013SO-24-A
Operating temperature [°C]	-10 ... +130	-10 ... +130	-10 ... +130	-10 ... +130	-10 ... +130	-10 ... +130
Protection to IEC 60529	IP67 *	IP67 *	IP67 *	IP67 *	IP67 *	IP67 *
Weight [kg]	3.15	4.3	4.3	3.15	4.3	4.3

*with purged air (max. 0,5 bar)

TECHNICAL DRAWINGS

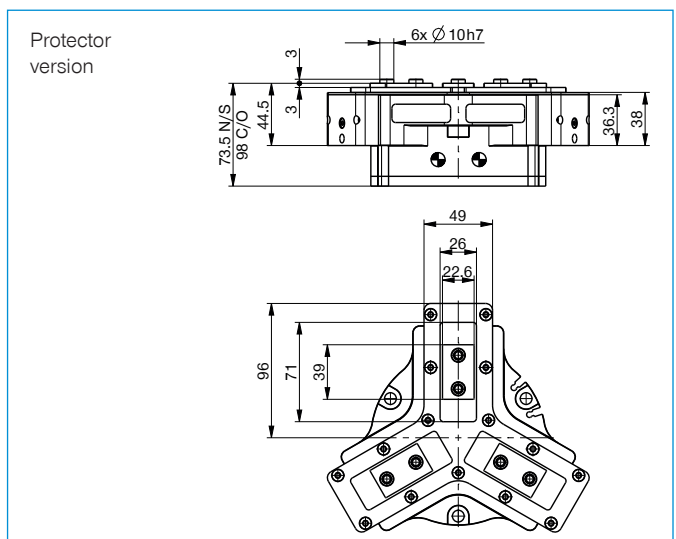
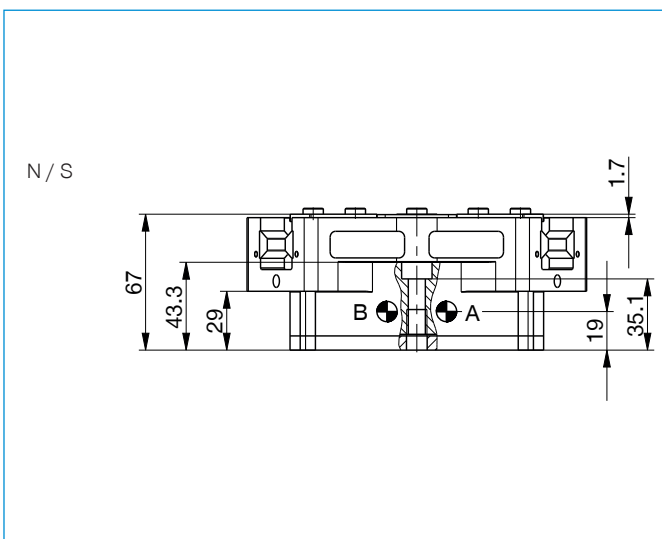
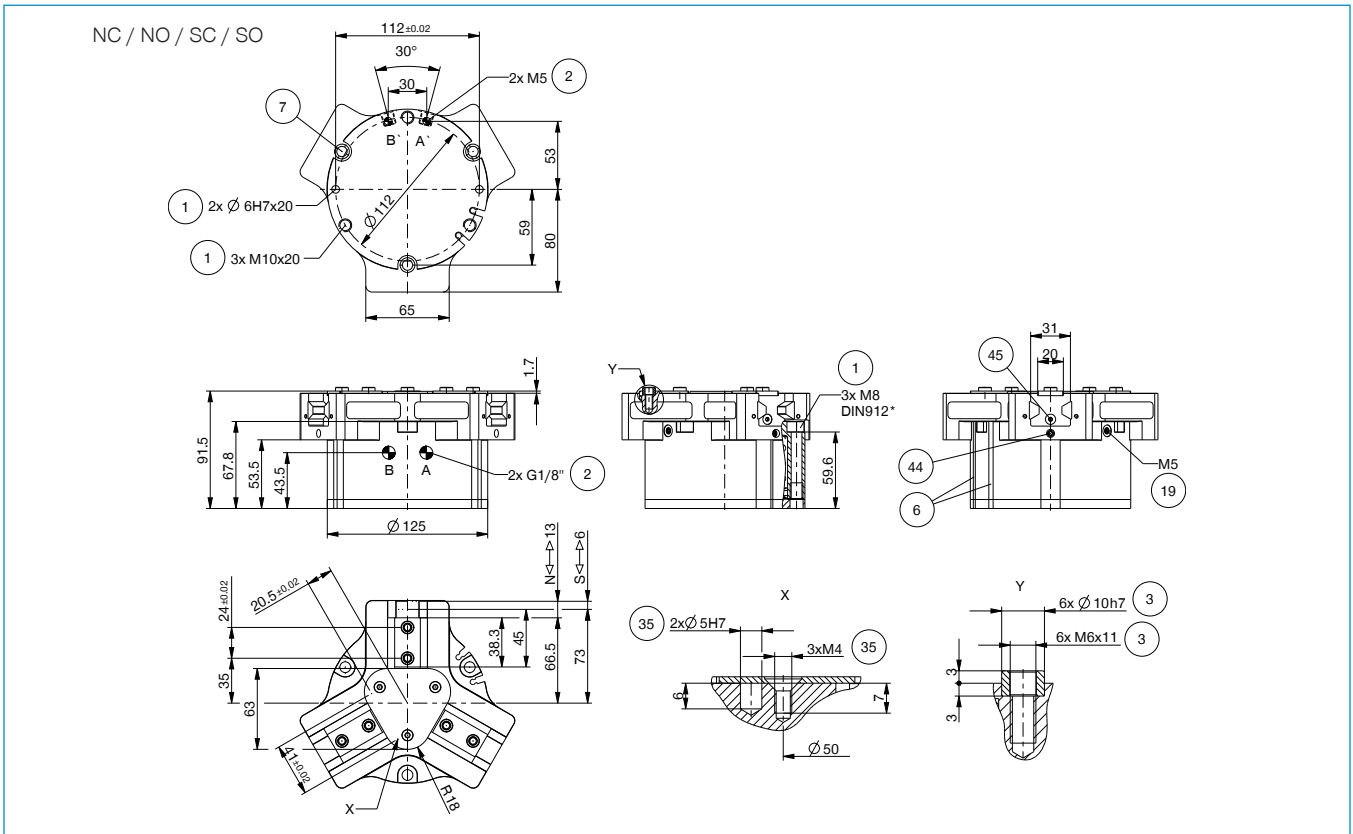

- | | |
|--|---------------------------------------|
| ① Gripper attachment | ③⑨ Gripper |
| ② Energy supply | ④④ Clamp for sensor |
| ③ Fixing for gripper finger | ④⑤ Switch cam adjustment |
| ⑥ Integrated slot for magnetic field sensor | ① Air connection (close) |
| ⑦ Mounting block | ② Air connection (open) |
| ⑱ Air purge connection option | ③ Air connection, alternative (close) |
| ⑳ Attachment option for customer-specific fittings | ④ Air connection, alternative (open) |
| ㉑ Adapter | |

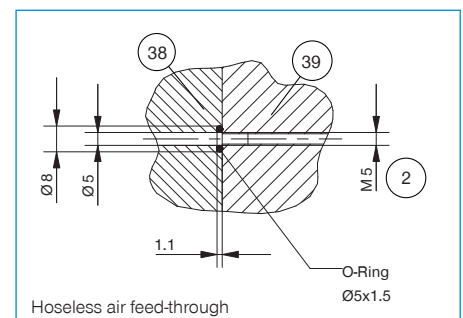

3-JAW CONCENTRIC GRIPPERS

INSTALLATION SIZE GPD5013

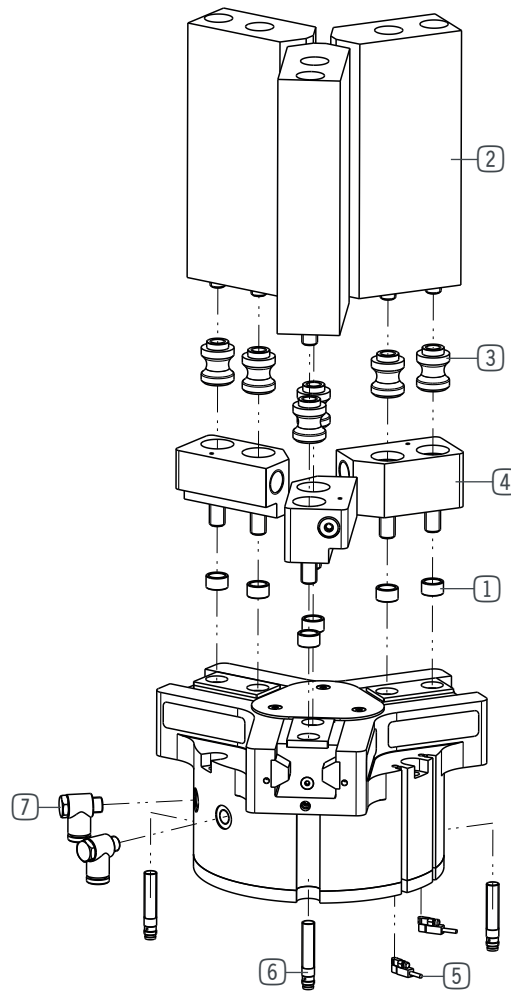

► INCLUDED IN DELIVERY



Centering Disc

018187

RECOMMENDED ACCESSORIES



Universal jaw aluminium

UB5013AL



Universal jaw steel

UB5013ST



Aluminum adjustment jaw

EB5013AL



Steel adjustment jaw

EB5013ST



Changeable jaw, loose-part-set

WB5013L



Changeable jaw, fix-part

WB5013F



Pressure piece N / S

ADS5013-01



Pressure piece NC / NO / SC / SO

ADS5013-02



Inductive proximity switch - Connector M8

NJ8-E2S



Magnetic field sensor Angled Cable 0,3 m - Connector M8

MFS103SKHC

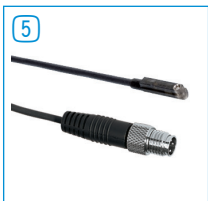

Magnetic field sensor Straight Cable 0,3 m - Connector M8

MFS204SKHC



2-Position-Sensor Cable 0,3 m - Connector M8

MFSP2SKHC-02



Plug-in connector Straight Cable 5m - Socket M8 (female)

KAG500



Angled Fittings - Quick Connect Style

WV1-8X6



Pressure Safety Valve

DSV1-8

TECHNICAL DRAWINGS ACCESSORIES

One universal jaw is required for each gripper jaw **2**

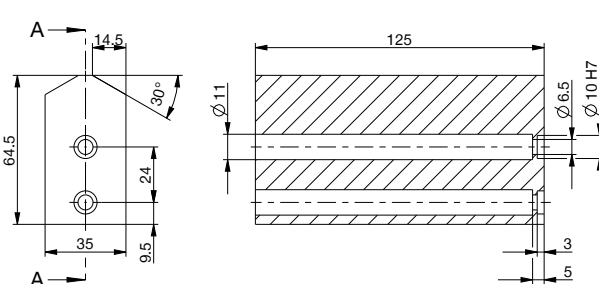

For each gripper jaw, one interchangeable jaw loose part set **3** and one interchangeable jaw fixed part **4** are needed

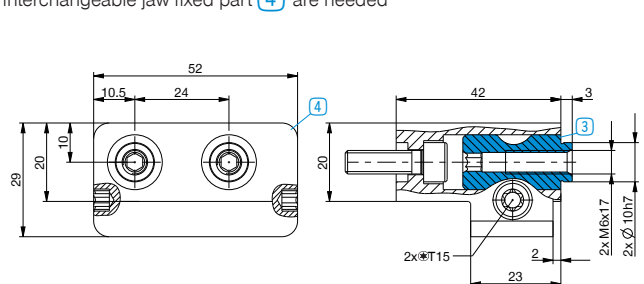

Gripper is fastened via the **pressure piece**

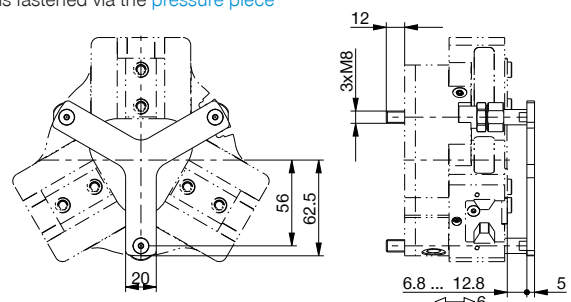

Total spring force min. / max. [N]: 60 / 124

3-JAW CONCENTRIC GRIPPERS

SERIES GPD5000

▶ PRODUCT ADVANTAGES

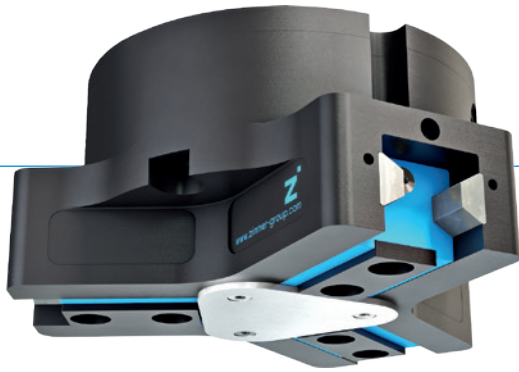

“The Universal One”

- ▶ Up to 30% more gripping force than the benchmark
- ▶ 10% more static forces and moments than the benchmark
- ▶ Gripper fingers up to 10% longer than the benchmark
- ▶ Gripper fingers weight up to 15% higher than the benchmark
- ▶ Sealed guide IP64 / Protector version IP67 (with purged air)
- ▶ Protected against corrosion
- ▶ Up to 30 million cycles without maintenance

▶ THE BEST PRODUCT FOR YOUR APPLICATION



▶ Our products welcome the challenge!

Extreme conditions, all over the world—our tried and tested components and systems give you endless possibilities.

Find the best product for your specific use:

www.zimmer-group.de

HOW TO ORDER CORRECTLY

- ▶ The product order numbers are arranged according to this diagram:

Order no.	GPD5010	<input type="checkbox"/>	<input type="checkbox"/>	- <input type="checkbox"/>	-A
Basis version	N				
High force	S				
For external gripping, self-locking, spring closing			C		
For internal gripping, self-locking, spring opening			O		
temperature-resistant version to 130 °C					20
Protector version IP67 for use in adverse environments (with purged air)					21
temperature-resistant protector version IP67 for use in adverse environments (with purged air) to 130 °C					24



► BENEFITS IN DETAIL

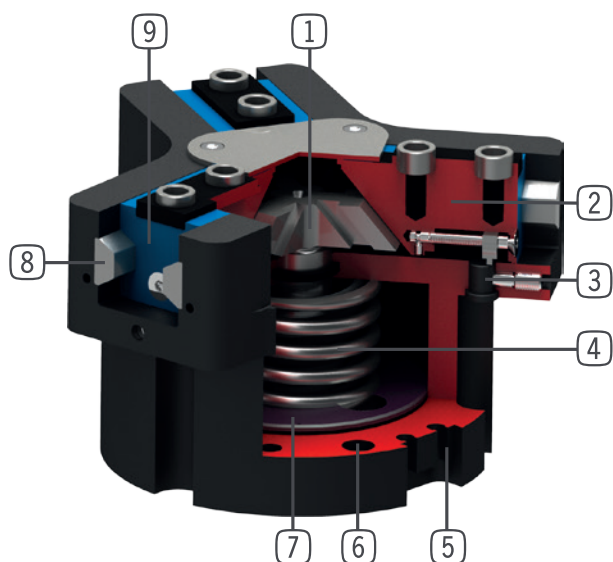

- ① **Wedge hook mechanism**
 - high forces and moments capacity
 - Synchronized gripper jaw movement
- ② **Gripper jaw**
 - Gripper fingers mounted using removable centring sleeves
 - Lubricated for life via incorporated lubrication slots
- ③ **Mounting block**
 - mounting for inductive proximity switch
- ④ **Integrated gripping force safety device**
 - Spring built into cylinder chamber as an energy store
- ⑤ **Sensing slot**
 - mounting and positioning of magnetic field sensors
- ⑥ **Mounting and positioning**
 - Alternatively, on several sides for customized mounting
 - Pneumatic and electrical versions identical apart from height
- ⑦ **Drive**
 - Double-acting pneumatic rotor cylinder
- ⑧ **Steel Linear Guide**
 - Steel in steel guide
 - Enables use of extremely long gripper fingers
- ⑨ **Dual lip seal**
 - IP64 and up to IP67 (with purged air) for Protector version
 - Prevents grease from being squeezed out, increasing service life

► SERIES CHARACTERISTICS



Number of installation sizes	11
Stroke per jaw	2,5 mm - 45 mm
Gripping force	310 N - 72500 N
Weight	0,14 kg - 88 kg
AP class	5



30 million maintenance-free cycles (max.)



High-strength S



IP67



Temperature-resistant



Spring closing C



Inductive sensor



Corrosion resistance



Purged air



Spring opening O



IP64



Magnetic field sensor