

# 2-JAW PARALLEL GRIPPERS

## INSTALLATION SIZE GP416

1

### ▶ PRODUCT SPECIFICATIONS



#### ▶ Gripping force diagram

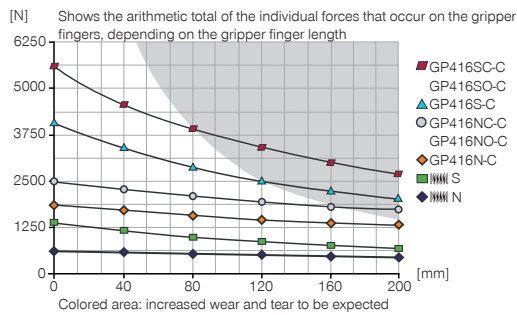

#### ▶ Forces and moments

Displays static forces and moments that can also have an effect, besides the gripping force.

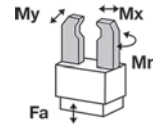

Mr [Nm]	140
Mx [Nm]	160
My [Nm]	180
Fa [N]	5000

### ▶ INCLUDED IN DELIVERY



Mounting block

KB8K



Centering Disc

DST41600

### ▶ RECOMMENDED ACCESSORIES



Universal Jaw Aluminium

UB416



Universal Jaw Steel

UB416ST



Alternate proximity bracket

KHA416-B-8



Magnetic field sensor  
Angled Cable 0,3 m -  
Connector M8  
MFS103SKHC



Magnetic field sensor  
Straight Cable 0,3 m -  
Connector M8  
MFS204SKHC



2-Position-Sensor Cable  
0,3 m - Connector M8  
MFSP2SKHC-02



Plug-in connector Straight Ca-  
ble 5m - Socket M8 (female)  
KAG500



Straight Fittings - Quick  
Connect Style  
GV1-8X6



Angled Fittings - Quick  
Connect Style  
WV1-8X6



Pressure Safety Valve  
DSV1-8

Order no.	▶ Technical Data*					
	GP416N-C	GP416NC-C	GP416NO-C	GP416S-C	GP416SC-C	GP416SO-C
Stroke per jaw [mm]	16	16	16	8	8	8
Gripping force in closing [N]	1860	2490		4160	5560	
Gripping force in opening [N]	1960		2590	4390		5780
Gripping force secured by spring min. [N]		630	630		1400	1400
Closing time [s]	0.2	0.15	0.25	0.2	0.15	0.25
Opening time [s]	0.2	0.25	0.15	0.2	0.25	0.15
Repetition accuracy +/- [mm]	0.01	0.01	0.01	0.01	0.01	0.01
Operating pressure min. [bar]	3	4	4	3	4	4
Operating pressure max. [bar]	8	8	8	8	8	8
Max. operating pressure for sealing air [bar]	0.5	0.5	0.5	0.5	0.5	0.5
Operating temperature min. [°C]	5	5	5	5	5	5
Operating temperature max. [°C]	+80	+80	+80	+80	+80	+80
Air volume per cycle [cm <sup>3</sup> ]	268	477	477	268	477	477
Weight [kg]	2.9	3.4	3.4	2.9	3.4	3.4

\*All data measured at 6 bar

NC / NO / SC / SO

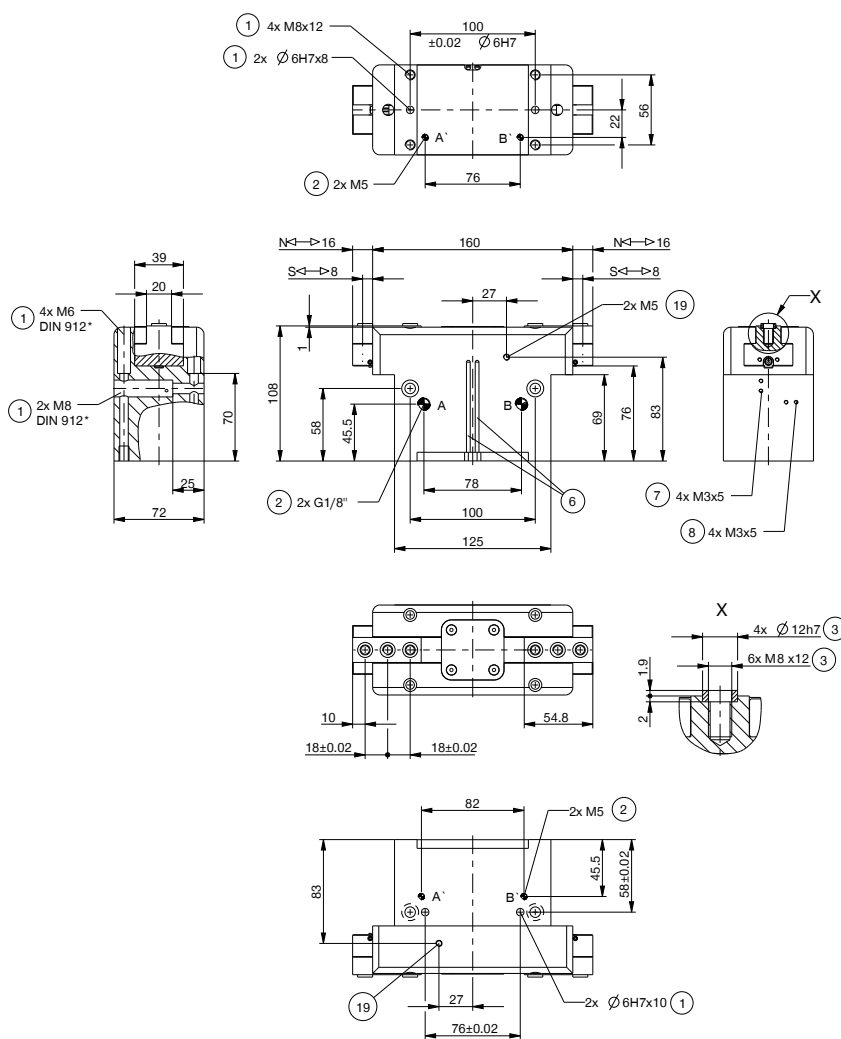

- ① Gripper attachment
- ② Energy supply
- ③ Fixing for gripper finger
- ⑥ Integrated slot for magnetic field sensor
- ⑦ Fixing for mounting block
- ⑧ Fixing clamping bracket (KHA)
- ⑱ Air purge connection option
- ⑳ Adapter
- ㉑ Gripper
- Ⓐ Air connection (close)
- Ⓑ Air connection (open)
- Ⓐ Air connection, alternative (close)
- Ⓑ Air connection, alternative (open)

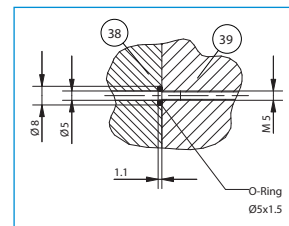

Hoseless air feed-through

N / S

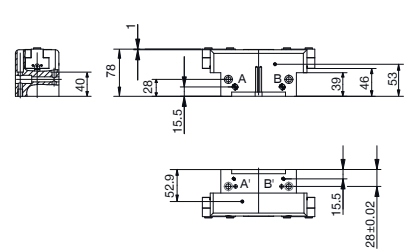

# 2-JAW PARALLEL GRIPPERS

## SERIES GP400

1

Series GP400 / 2-Jaw Parallel Grippers / pneumatic / Grippers

### ▶ PRODUCT ADVANTAGES

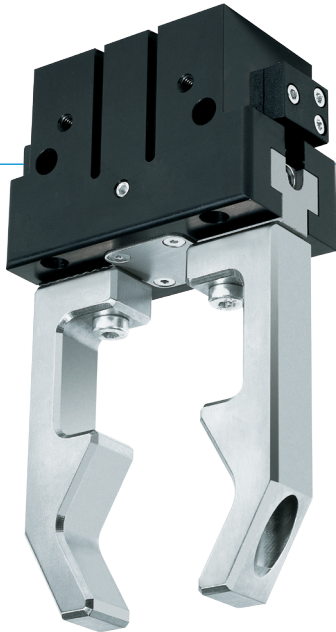

#### “The economical”

##### ▶ Concentration on the essentials

The most economic type of gripping: This is how you reduce your production costs

##### ▶ Proven T slot guide

This established and proven guiding technology stands for the highest process reliability like no other

##### ▶ Compact structure

Reduces the interference contours for your application

### ▶ THE BEST PRODUCT FOR YOUR APPLICATION

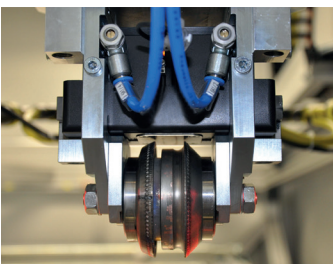

##### ▶ Our products love the challenge!

Extreme conditions, all over the world—our tried and tested components and systems give you limitless possibilities:

Find the best product for your specific use:

[www.zimmer-group.com](http://www.zimmer-group.com)

#### HOW TO ORDER CORRECTLY

- ▶ The product order numbers are arranged according to this diagram:

<b>Order no.</b>	<b>GP410</b>	<input type="checkbox"/>	<input type="checkbox"/>	<b>-C</b>
Long stroke		<b>N</b>		
High force		<b>S</b>		
For external gripping, self-locking, spring closing			<b>C</b>	
For internal gripping, self-locking, spring opening			<b>O</b>	



## ► BENEFITS IN DETAIL

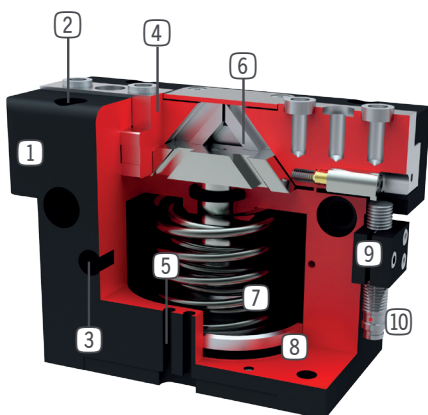

- ① **Robust, lightweight housing**  
- Hard-coated aluminum alloy
- ② **Mounting and positioning**  
- mounting possible from several sides for versatile positioning
- ③ **Energy supply**  
- possible from several sides
- ④ **Gripper jaw**  
- individual gripper finger mounting
- ⑤ **Sensing slot**  
- mounting and positioning of magnetic field sensors
- ⑥ **Wedge hook mechanism**  
- synchronized the movement of the gripper jaws
- ⑦ **Integrated gripping force safety device**  
- spring integrated into cylinder as energy storage
- ⑧ **Position sensing**  
- permanent magnet for direct monitoring of piston movement
- ⑨ **Mounting block**  
- mounting for inductive proximity switch (10)

## ► SERIES CHARACTERISTICS

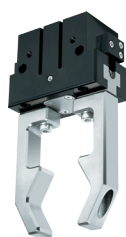

Number of installation sizes	9
Stroke per jaw	3 mm - 30 mm
Gripping force	85 N - 19275 N
Weight	0,08 kg - 18,9 kg
AP class	3



10 million maintenance-free cycles (max.)



High-strength S



Magnetic field sensor



Spring closing C



Inductive sensor



Purged air



Spring opening O



IP40