

2-JAW PARALLEL GRIPPERS

INSTALLATION SIZE GP412

1

Installation size GP412 / 2-Jaw Parallel Grippers / pneumatic / Grippers

▶ PRODUCT SPECIFICATIONS

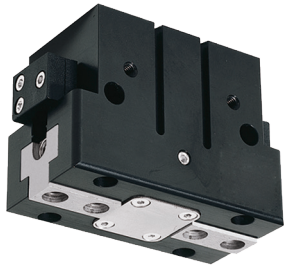

▶ Gripping force diagram

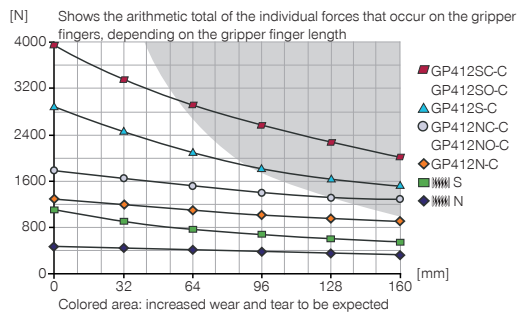

▶ Forces and moments

Displays static forces and moments that can also have an effect, besides the gripping force.

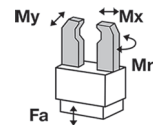

Mr [Nm]	100
Mx [Nm]	120
My [Nm]	120
Fa [N]	3200

▶ INCLUDED IN DELIVERY

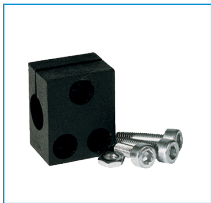

Mounting block

KB8K



Centering Disc

DST41000

▶ RECOMMENDED ACCESSORIES



Universal Jaw Aluminium

UB412



Universal Jaw Steel

UB412ST



Alternate proximity bracket

KHA412-B-8



Magnetic field sensor
Angled Cable 0,3 m -
Connector M8
MFS103SKHC



Magnetic field sensor
Straight Cable 0,3 m -
Connector M8
MFS204SKHC



2-Position-Sensor Cable
0,3 m - Connector M8
MFSP2SKHC-02

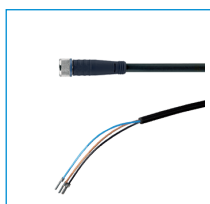

Plug-in connector Straight Cable
5m - Socket M8 (female)
KAG500



Straight Fittings - Quick
Connect Style
GV1-8X6



Angled Fittings - Quick
Connect Style
WV1-8X6



Pressure Safety Valve
DSV1-8

Order no.	▶ Technical Data*					
	GP412N-C	GP412NC-C	GP412NO-C	GP412S-C	GP412SC-C	GP412SO-C
Stroke per jaw [mm]	12	12	12	6	6	6
Gripping force in closing [N]	1290	1780		2890	3960	
Gripping force in opening [N]	1370		1850	3050		4130
Gripping force secured by spring min. [N]		490	490		1080	1080
Closing time [s]	0.1	0.08	0.12	0.1	0.08	0.12
Opening time [s]	0.1	0.12	0.08	0.1	0.12	0.08
Repetition accuracy +/- [mm]	0.01	0.01	0.01	0.01	0.01	0.01
Operating pressure min. [bar]	3	4	4	3	4	4
Operating pressure max. [bar]	8	8	8	8	8	8
Max. operating pressure for sealing air [bar]	0.5	0.5	0.5	0.5	0.5	0.5
Operating temperature min. [°C]	5	5	5	5	5	5
Operating temperature max. [°C]	+80	+80	+80	+80	+80	+80
Air volume per cycle [cm ³]	80	148	148	80	148	148
Weight [kg]	1.5	1.78	1.78	1.5	1.78	1.78

*All data measured at 6 bar

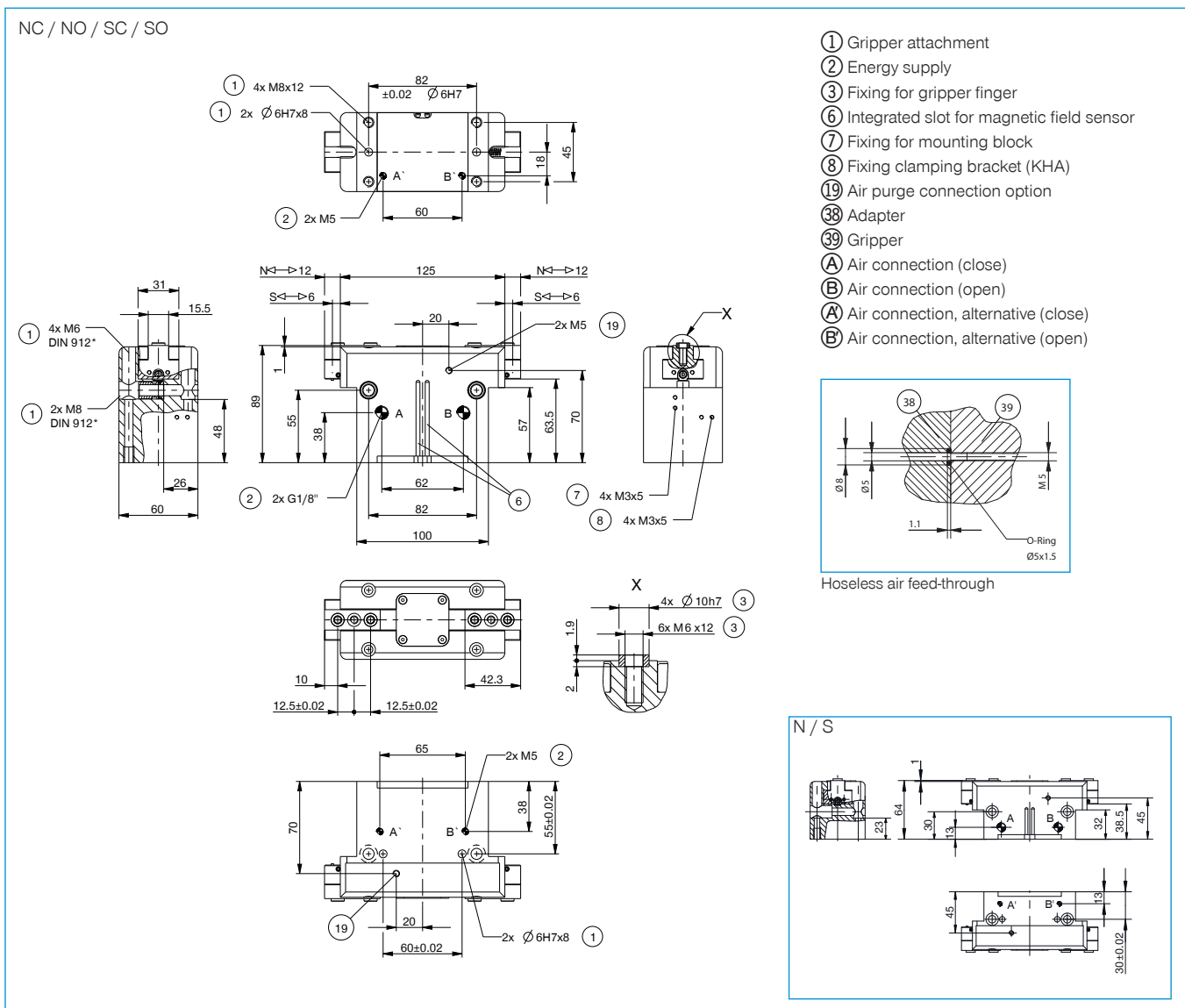

2-JAW PARALLEL GRIPPERS

SERIES GP400

1

Series GP400 / 2-Jaw Parallel Grippers / pneumatic / Grippers

▶ PRODUCT ADVANTAGES

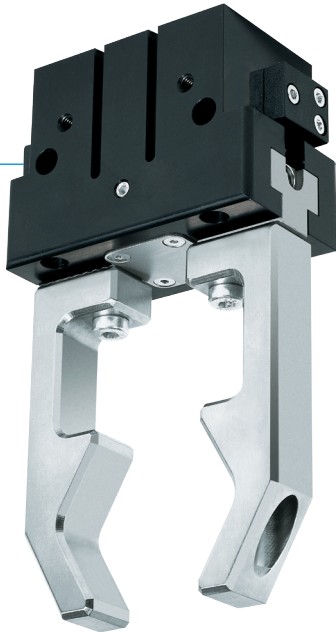

“The economical”

▶ Concentration on the essentials

The most economic type of gripping: This is how you reduce your production costs

▶ Proven T slot guide

This established and proven guiding technology stands for the highest process reliability like no other

▶ Compact structure

Reduces the interference contours for your application

▶ THE BEST PRODUCT FOR YOUR APPLICATION

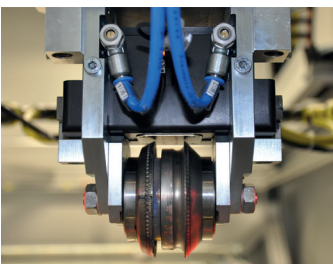

▶ Our products love the challenge!

Extreme conditions, all over the world—our tried and tested components and systems give you limitless possibilities:

Find the best product for your specific use:

www.zimmer-group.com

HOW TO ORDER CORRECTLY

▶ The product order numbers are arranged according to this diagram:

Order no.	GP410	<input type="checkbox"/>	<input type="checkbox"/>	-C
Long stroke		N		
High force		S		
For external gripping, self-locking, spring closing			C	
For internal gripping, self-locking, spring opening			O	



► BENEFITS IN DETAIL

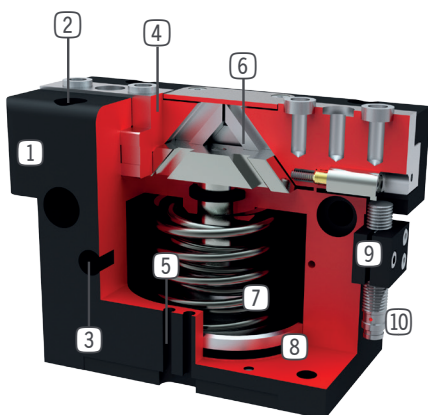

- ① **Robust, lightweight housing**
- Hard-coated aluminum alloy
- ② **Mounting and positioning**
- mounting possible from several sides for versatile positioning
- ③ **Energy supply**
- possible from several sides
- ④ **Gripper jaw**
- individual gripper finger mounting
- ⑤ **Sensing slot**
- mounting and positioning of magnetic field sensors
- ⑥ **Wedge hook mechanism**
- synchronized the movement of the gripper jaws
- ⑦ **Integrated gripping force safety device**
- spring integrated into cylinder as energy storage
- ⑧ **Position sensing**
- permanent magnet for direct monitoring of piston movement
- ⑨ **Mounting block**
- mounting for inductive proximity switch (10)

► SERIES CHARACTERISTICS

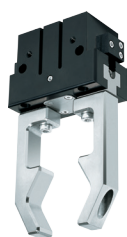

Number of installation sizes	9
Stroke per jaw	3 mm - 30 mm
Gripping force	85 N - 19275 N
Weight	0,08 kg - 18,9 kg
AP class	3



10 million maintenance-free cycles (max.)



High-strength S



Magnetic field sensor



Spring closing C



Inductive sensor



Purged air



Spring opening O



IP40