

2-JAW PARALLEL GRIPPERS

INSTALLATION SIZE GP240

1

Installation size GP240 / 2-Jaw Parallel Grippers / pneumatic / Grippers

▶ PRODUCT SPECIFICATIONS

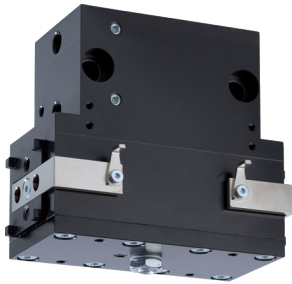

▶ Gripping force diagram

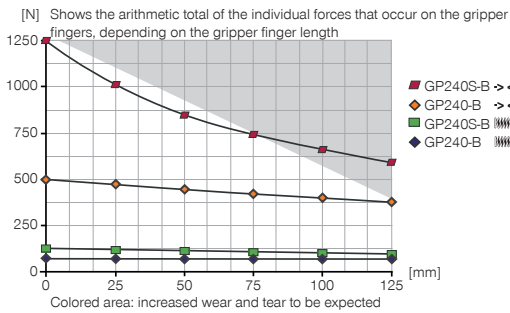

▶ Forces and moments

Displays static forces and moments that can also have an effect, besides the gripping force.

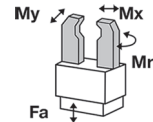

Mr [Nm]	15
Mx [Nm]	30
My [Nm]	15
Fa [N]	400

▶ INCLUDED IN DELIVERY

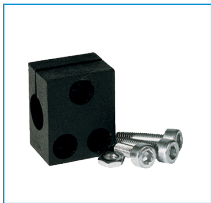

Mounting block

KB8K

▶ RECOMMENDED ACCESSORIES



Centering Disc

ZE30H7X4



Inductive proximity switch - Connector M8

NJ8-E2S



Magnetic field sensor
Angled Cable 0,3 m - Connector M8

MFS103SKHC



Magnetic field sensor
Straight Cable 0,3 m - Connector M8

MFS204SKHC



2-Position-Sensor Cable
0,3 m - Connector M8

MFSP2SKHC-02

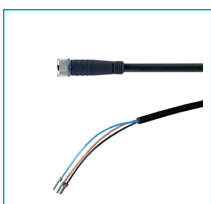

Plug-in connector Straight Cable 5m - Socket M8 (female)

KAG500



Straight Fittings - Quick Connect Style

GVM5



Angled Fittings - Quick Connect Style

WVM5

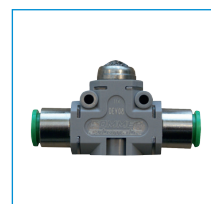

Quick Exhaust Valve

DEV04



Pressure Safety Valve

DSV1-8

Order no.	▶ Technical Data*			
	GP240-B	GP240-B-99	GP240S-B	GP240S-B-99
Stroke per jaw [mm]	20	20	8	8
Gripping force in closing [N]	510	435	1290	1105
Gripping force in opening [N]		435		1105
Gripping force secured by spring min. [N]	75		185	
Closing time [s]	0.1	0.08	0.1	0.08
Opening time [s]	0.1	0.08	0.1	0.08
Repetition accuracy +/- [mm]	0.05	0.05	0.05	0.05
Operating pressure min. [bar]	5	3	5	3
Operating pressure max. [bar]	8	8	8	8
Operating temperature min. [°C]	5	5	5	5
Operating temperature max. [°C]	+80	+80	+80	+80
Air volume per cycle [cm ³]	49	49	49	49
Weight [kg]	1.2	1.2	1.2	1.2

*All data measured at 6 bar

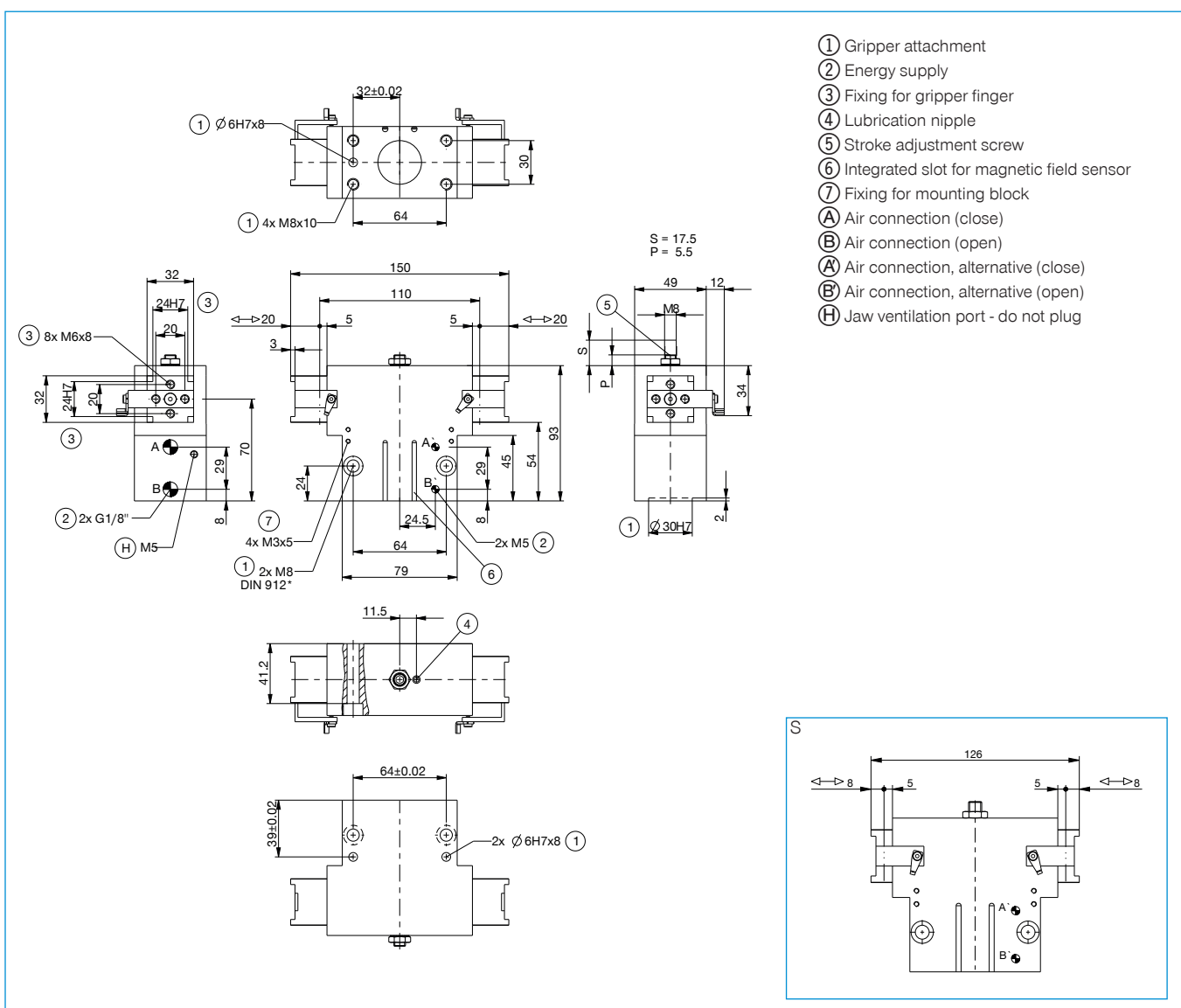

2-JAW PARALLEL GRIPPERS

SERIES GP200

1

Series GP200 / 2-Jaw Parallel Grippers / pneumatic / Grippers

▶ PRODUCT ADVANTAGES

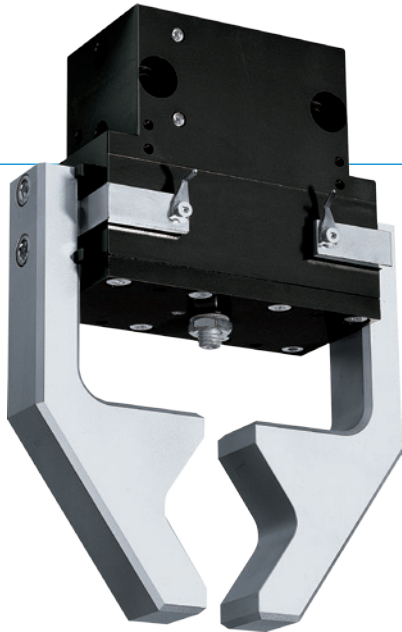

“The variable”

▶ Smooth stroke configuration

An adjusting screw allows you to adjust the stroke to your specific application

▶ Proven technology

We have more than 20 years of proven reliability, which ensures uninterrupted production for you

▶ Dirt protection

Using the scrapers on the guides, you can reliably use the gripper even under the harshest conditions

▶ THE BEST PRODUCT FOR YOUR APPLICATION

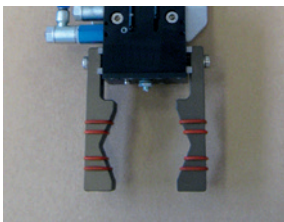

▶ Our products welcome the challenge!

Extreme conditions, all over the world—our tried and tested components and systems give you endless possibilities.

Find the best product for your specific use:

www.zimmer-group.de

HOW TO ORDER CORRECTLY

- ▶ The product order numbers are arranged according to this diagram:

Order no.	GP280	<input type="checkbox"/>	<input type="checkbox"/>	
High force		S		
Without intergrated spring			-99	



BENEFITS IN DETAIL

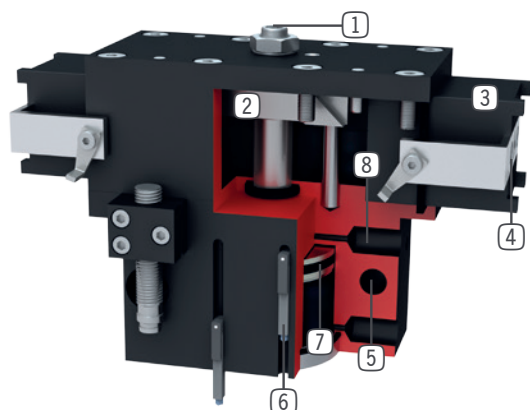

- 1 Stroke adjustment**
 - infinitely adjustable in „open“ movement
 - adjusting screw in delivery
- 2 Wedge hook mechanism**
 - synchronized the movement of the gripper jaws
 - high force transfer
- 3 Square guide**
 - high forces and moments capacity
- 4 Gripper jaw**
 - individual gripper finger mounting
- 5 Mounting and positioning**
 - mounting possible from several sides for versatile positioning
- 6 Sensing slot**
 - mounting and positioning of magnetic field sensors
- 7 Drive**
 - double-acting pneumatic cylinder
- 8 Energy supply**
 - possible from several sides

SERIES CHARACTERISTICS



Number of installation sizes	4
Stroke per jaw	6 mm - 40 mm
Gripping force	160 N - 4500 N
Weight	0,33 kg - 8,3 kg
AP class	3



10 million maintenance-free cycles (max.)



Spring closing C



High-strength S



Inductive sensor



IP40



Magnetic field sensor



Purged air