

2-JAW PARALLEL GRIPPERS WITH LONG STROKE INSTALLATION SIZE GH62150

1

Installation size GH62150 / 2-Jaw Parallel Grippers with Long Stroke / pneumatic / Grippers

▶ PRODUCT SPECIFICATIONS

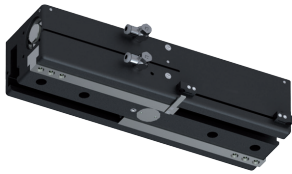

▶ Gripping force diagram

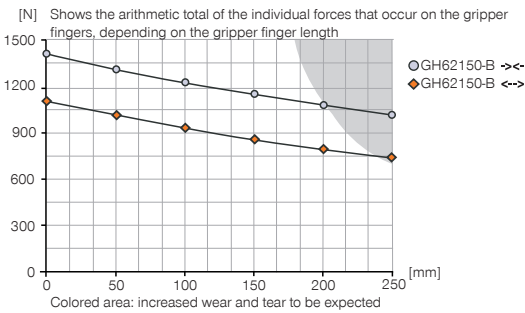

▶ Forces and moments

Displays static forces and moments that can also have an effect, besides the gripping force.

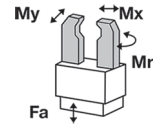

Mr [Nm]	180
Mx [Nm]	225
My [Nm]	160
Fa [N]	3000

▶ INCLUDED IN DELIVERY



Mounting block

KB8-28



Centering Disc

DST41000



Flow Control Valves - with Swivel joint

DRV1-8X8

▶ RECOMMENDED ACCESSORIES



Universal Jaw Aluminium

UB6200-B



Alternate proximity bracket

KHA62150-B-8

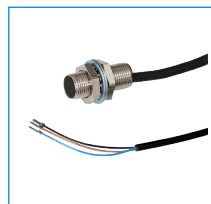

Inductive proximity switch - Cable 5 m

NJ8-E2



Inductive proximity switch - Connector M8

NJ8-E2S



Magnetic field sensor Angled Cable 5 m

MFS103KHC



Magnetic field sensor Angled Cable 0,3 m - Connector M8

MFS103SKHC



Magnetic field sensor Straight Cable 5 m

MFS204KHC



Magnetic field sensor Straight Cable 0,3 m - Connector M8

MFS204SKHC

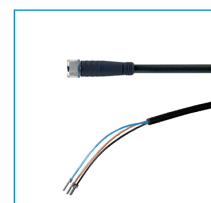

Plug-in connector Straight Cable 5m - Socket M8 (female)

KAG500

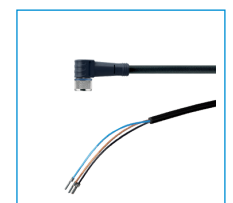

Plug-in connector Angled Cable 5m - Socket M8 (female)

KAW500

Order no.	► Technical Data*	
	GH62150-B	GHK62150
Stroke per jaw [mm]	150	150
Gripping force in closing [N]	1400	1400
Gripping force in opening [N]	1100	1100
Retention force in case of drop in pressure [N]		640
Closing time [s]	0.5	0.5
Opening time [s]	0.5	0.5
Repetition accuracy +/- [mm]	0.05	0.05
Operating pressure min. [bar]	3	3
Operating pressure max. [bar]	8	8
Operating temperature min. [°C]	5	5
Operating temperature max. [°C]	+80	+80
Air volume per cycle [cm ³]	687	687
Weight [kg]	7.5	8

*All data measured at 6 bar
GHK series, see page 221

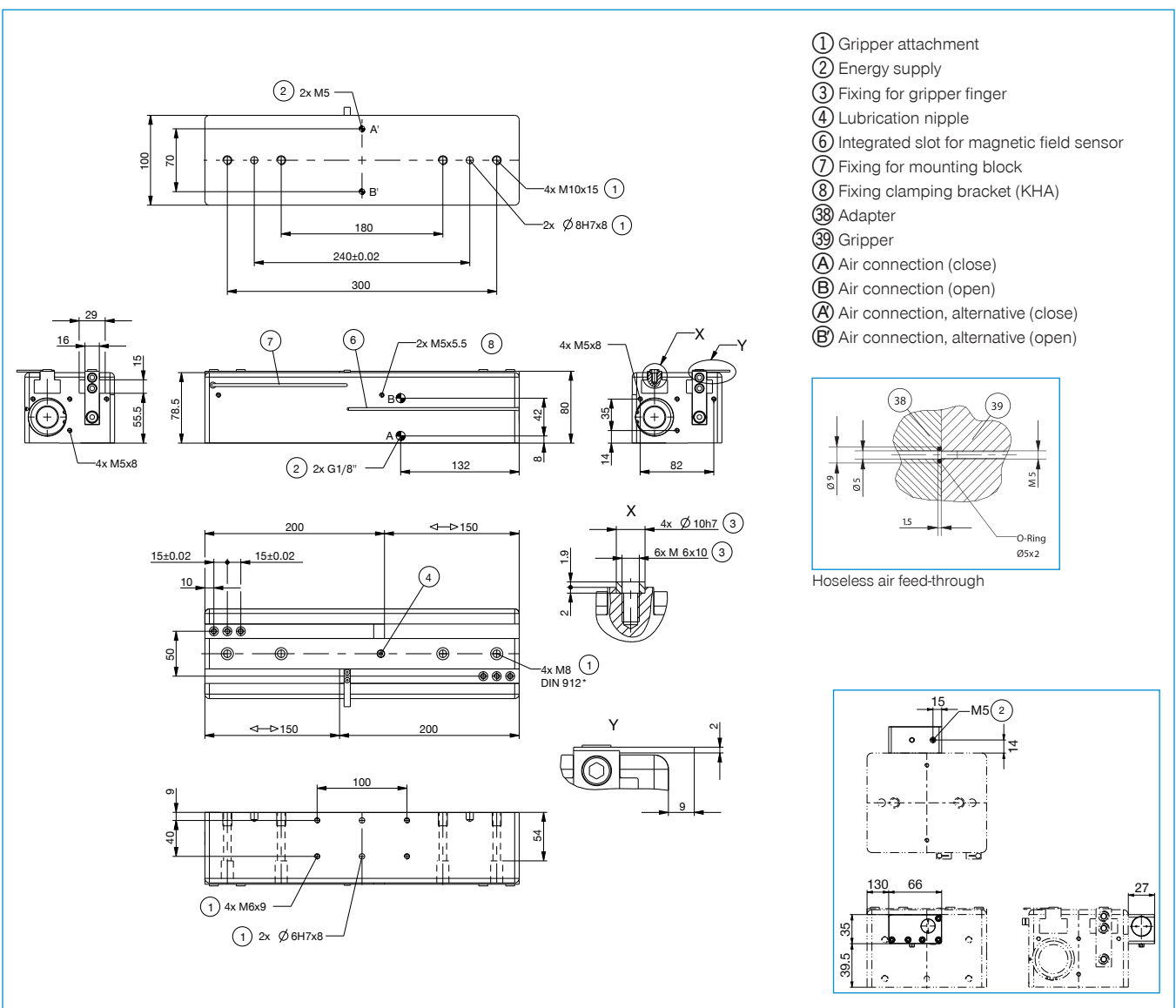

2-JAW PARALLEL GRIPPERS WITH LONG STROKE SERIES GH6000

1

Series GH6000 / 2-Jaw Parallel Grippers with Long Stroke / pneumatic / Grippers

▶ PRODUCT ADVANTAGES

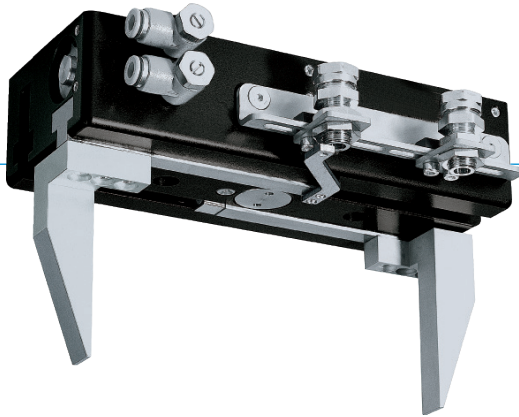

“The robust”

▶ **Gripper jaws may be up to 25% longer in comparison to the benchmark**

The highest force and torque measurement enables flexible for maximum dynamics

▶ **Over 30% more powerful than the benchmark**

Optimisation of weight and force reduces your application costs since all components can have a smaller scale

▶ **Failure-free continuous operation**

Our uncompromising „Made in Germany“ quality guarantees up to 10 million maintenance-free cycles

▶ THE BEST PRODUCT FOR YOUR APPLICATION



▶ **Our products welcome the challenge!**

Extreme conditions, all over the world—our tried and tested components and systems give you endless possibilities.

Find the best product for your specific use:

www.zimmer-group.de



► BENEFITS IN DETAIL

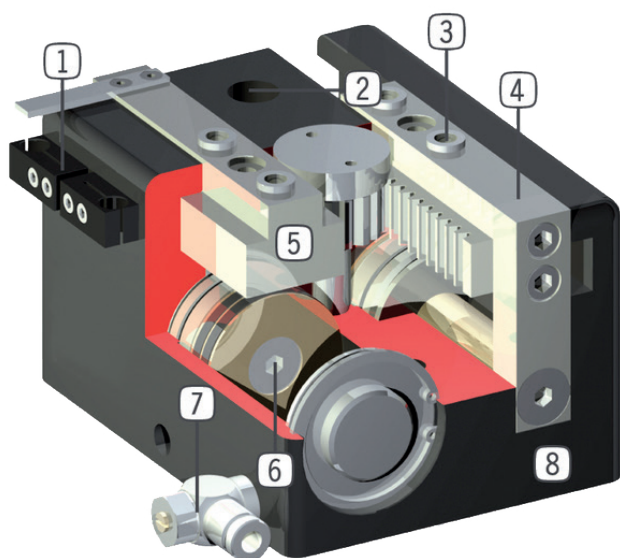

- ① **Mounting block**
 - mounting for inductive proximity switch
- ② **Mounting and positioning**
 - mounting possible from several sides for versatile positioning
- ③ **Removable centering sleeves**
 - quick and economical positioning of the gripper fingers
- ④ **Gripper jaw**
 - individual gripper finger mounting
- ⑤ **Precise long T-Slot guides**
 - high forces and moments capacity
- ⑥ **Drive**
 - two double-acting pneumatic cylinders
 - synchronized by gearwheel
- ⑦ **Energy supply**
 - possible from several sides
 - CAUTION: always operate long stroke gripper with supplied exhaust air flow control valve (speed regulation)
- ⑧ **Robust, lightweight housing**
 - Hard-coated aluminum alloy

► SERIES CHARACTERISTICS



Number of installation sizes	5
Stroke per jaw	20 mm - 200 mm
Gripping force	120 N - 3400 N
Weight	0,3 kg - 23,8 kg
AP class	3



10 million maintenance-free cycles (max.)



Inductive sensor



IP40



Magnetic field sensor