

# 2-JAW PARALLEL GRIPPERS

## INSTALLATION SIZE GP12

1

Installation size GP12 / 2-Jaw Parallel Grippers / pneumatic / Grippers

### ▶ PRODUCT SPECIFICATIONS



#### ▶ Gripping force diagram

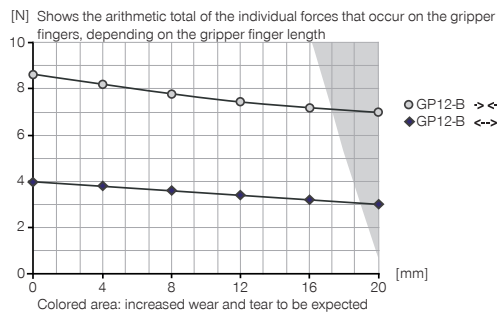

#### ▶ Forces and moments

Displays static forces and moments that can also have an effect, besides the gripping force.

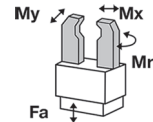

Mr [Nm]	0.15
Mx [Nm]	0.15
My [Nm]	0.15
Fa [N]	15

### ▶ RECOMMENDED ACCESSORIES



Universal Jaw Aluminium

UB12

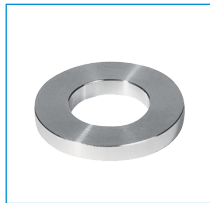

Centering Disc

ZE10H7X6



Mounting block

KB3M

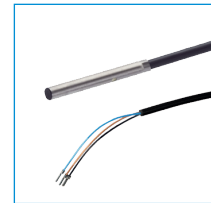

Inductive proximity switch  
- Cable 5 m

NJ3-E2



Inductive Proximity  
Switch Cable 0,3 m -  
Connector M8  
NJ3-E2SK

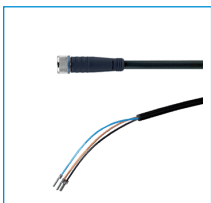

Plug-in connector Straight Ca-  
ble 5m - Socket M8 (female)

KAG500



Straight Fittings - Barb  
Style Connection

GVM3



Angled Fittings - Barb  
Style Connection

WVM3

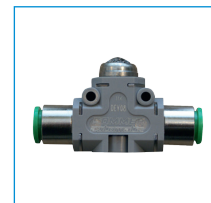

Quick Exhaust Valve

DEV04

Order no.	GP12-B
Stroke per jaw [mm]	3
Gripping force in closing [N]	8.4
Gripping force in opening [N]	4
Gripping force secured by spring min. [N]	
Closing time [s]	0.02
Opening time [s]	0.02
Repetition accuracy +/- [mm]	0.05
Operating pressure min. [bar]	3
Operating pressure max. [bar]	8
Operating temperature min. [°C]	5
Operating temperature max. [°C]	+80
Air volume per cycle [cm³]	0.4
Weight [kg]	0.033

\*All data measured at 6 bar

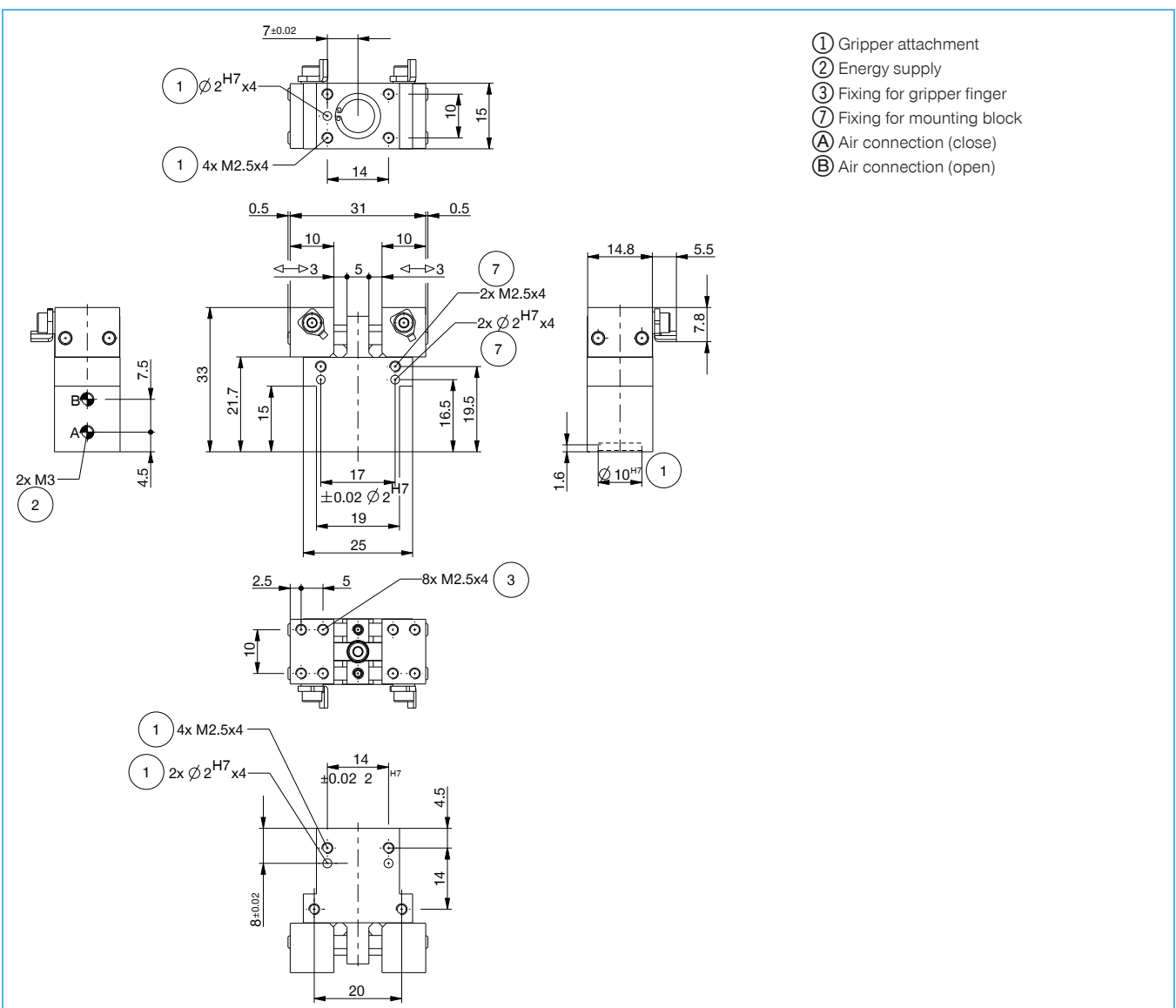

# 2-JAW PARALLEL GRIPPERS

## SERIES GP

1

Series GP / 2-Jaw Parallel Grippers / pneumatic / Grippers

### ▶ PRODUCT ADVANTAGES

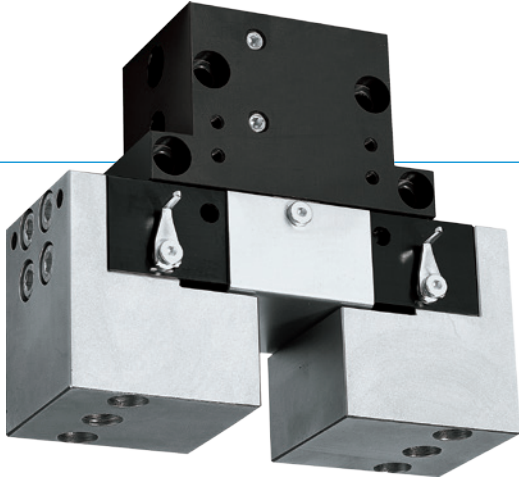

#### “The enduring”

##### ▶ Proven technology

We have more than 20 years of proven reliability, which ensures uninterrupted production for you

##### ▶ Very short cycle times

Low-friction circular guides enable very short cycle times and, therefore, high component output for your machine

##### ▶ Failure-free continuous operation

Our uncompromising „Made in Germany“ quality guarantees up to 10 million maintenance-free cycles

### ▶ THE BEST PRODUCT FOR YOUR APPLICATION

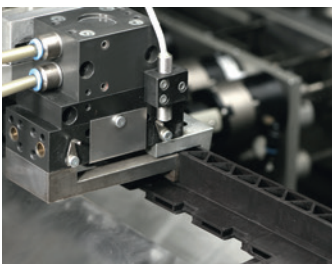

##### ▶ Our products welcome the challenge!

Extreme conditions, all over the world—our tried and tested components and systems give you endless possibilities.

Find the best product for your specific use:

[www.zimmer-group.de](http://www.zimmer-group.de)

#### HOW TO ORDER CORRECTLY

- ▶ The product order numbers are arranged according to this diagram:

<b>Order no.</b>	<b>GP45</b>	<input type="checkbox"/>	<b>-B</b>	
For external gripping, self-locking, spring closing		<b>S</b>		
Without intergrated spring				<b>-99</b>



## ► BENEFITS IN DETAIL

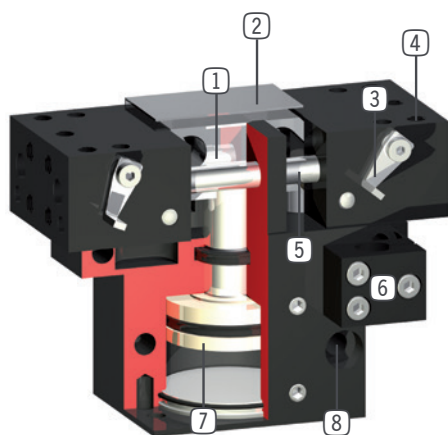

- ① **Wedge hook mechanism**
  - synchronized the movement of the gripper jaws
  - high force transfer
- ② **Cover plate**
  - to protect the guide and mechanics (from GP45)
- ③ **Adjustable switch cam**
  - for position sensing
- ④ **Gripper jaw**
  - individual gripper finger mounting
- ⑤ **Roller slide**
  - for low wear movement sequence
- ⑥ **Mounting block**
  - mounting for inductive proximity switch
- ⑦ **Drive**
  - double-acting pneumatic cylinder
- ⑧ **Mounting and positioning**
  - mounting possible from several sides for versatile positioning

## ► SERIES CHARACTERISTICS



Number of installation sizes	6
Stroke per jaw	3 mm - 13 mm
Gripping force	4 N - 5250 N
Weight	0,033 kg - 1,4 kg
AP class	2



10 million maintenance-free cycles (max.)



Spring closing C



Inductive sensor



IP30