

Prosilica GX

1920



- 240 MB/s with dual port LAG technology
- 3-axis motorized lens control
- 40 fps @ full resolution
- Various lens mount options

Description

2.8 Megapixel HD CCD camera with high frame rate - Dual port Gigabit Ethernet output

Prosilica GX1920/GX1920C is a high-resolution CCD camera with a Gigabit Ethernet interface (GigE Vision®). This camera incorporates the Sony ICX674 CCD sensor. This camera has two screw-captivated Gigabit Ethernet ports configured as a Link Aggregation Group (LAG) to provide a sustained maximum data rate of 240 MB per second. it can also work at half the bandwidth (120 MB/s) using a single cable.

Options:

- Nikon F-Mount (Factory conversion)
- Canon EF-Mount (Factory conversion via RS232 I/O)
- Optical filters (IR cut filter/Protection glass)

See the [Modular Concept](#) for lens mount and optical filter options.

Specifications

Prosilica GX	1920
Interface	IEEE 802.3 1000baseT
Resolution	1936 (H) × 1456 (V)
Sensor	Sony ICX674
Sensor type	CCD Progressive
Cell size	4.54 μm x 4.54 μm
Lens mount	C-Mount
Max frame rate at full resolution	40 fps
ADC	14 bit
Image buffer (RAM)	128 MByte
Output	

Prosilica GX	1920
Bit depth	14 (monochrome); 12 (color) bit
Mono modes	Mono8, Mono12, Mono12Packed, Mono14
Color modes RGB	RGB8Packed, BGR8Packed, RGBA8Packed, BGRA8Packed
Raw modes	BayerRG8, BayerRG12, BayerGR12Packed
General purpose inputs/outputs (GPIOs)	
Opto-isolated I/Os	2 inputs, 4 outputs
RS-232	1
Operating conditions/dimensions	
Operating temperature	0 °C to +50 °C ambient (without condensation)
Power requirements (DC)	5 to 24 VDC
Power consumption (@12 V)	5.3W (1 port); 6.2W (2 ports)
Mass	269 g
Body dimensions (L × W × H in mm)	108.1 × 53.3 × 33 (including connectors)
Regulations	CE, RoHS, REACH, WEEE, FCC, ICES

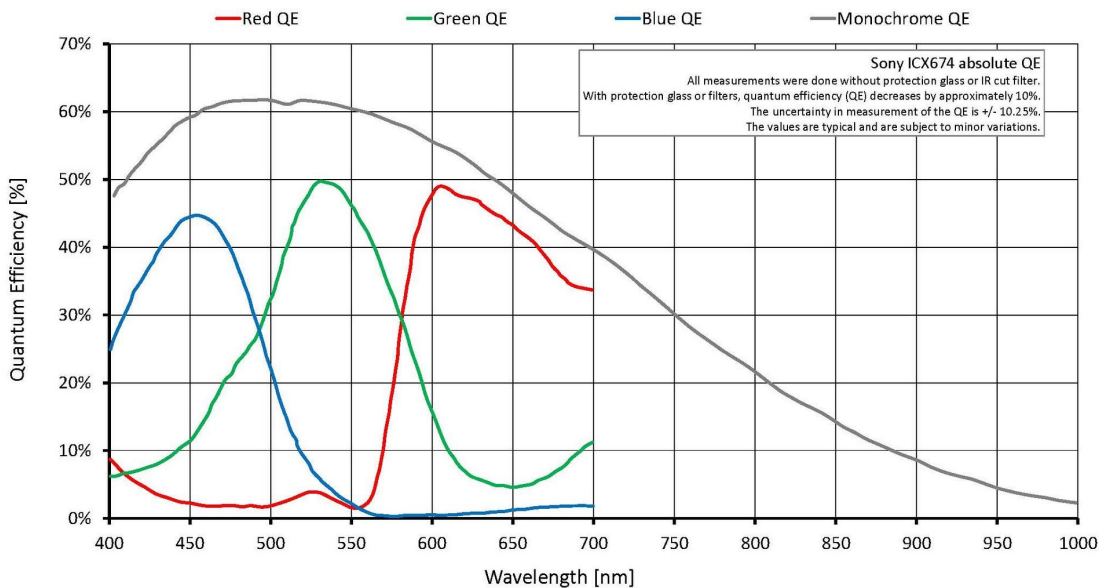

Features

Prosilica GX1920/GX1920C features include:

- 3-axis motorized lens control
- Video-type auto iris
- Region of interest (ROI), DSP subregion (selectable ROI for auto features)



- Binning
- Auto gain (manual gain control: 0 to 24 dB)
- Auto exposure (manual exposure controls: 10 #s to 26.8 s)
- Auto white balance
- StreamBytesPerSecond (easy bandwidth control)
- Stream hold
- Sync out modes: Trigger ready, input, exposing, readout, imaging, strobe, GPO
- Global shutter (digital shutter)
- Recorder and Multiframe acquisition modes
- Event channel
- Chunk data
- Storable user sets

Technical drawing

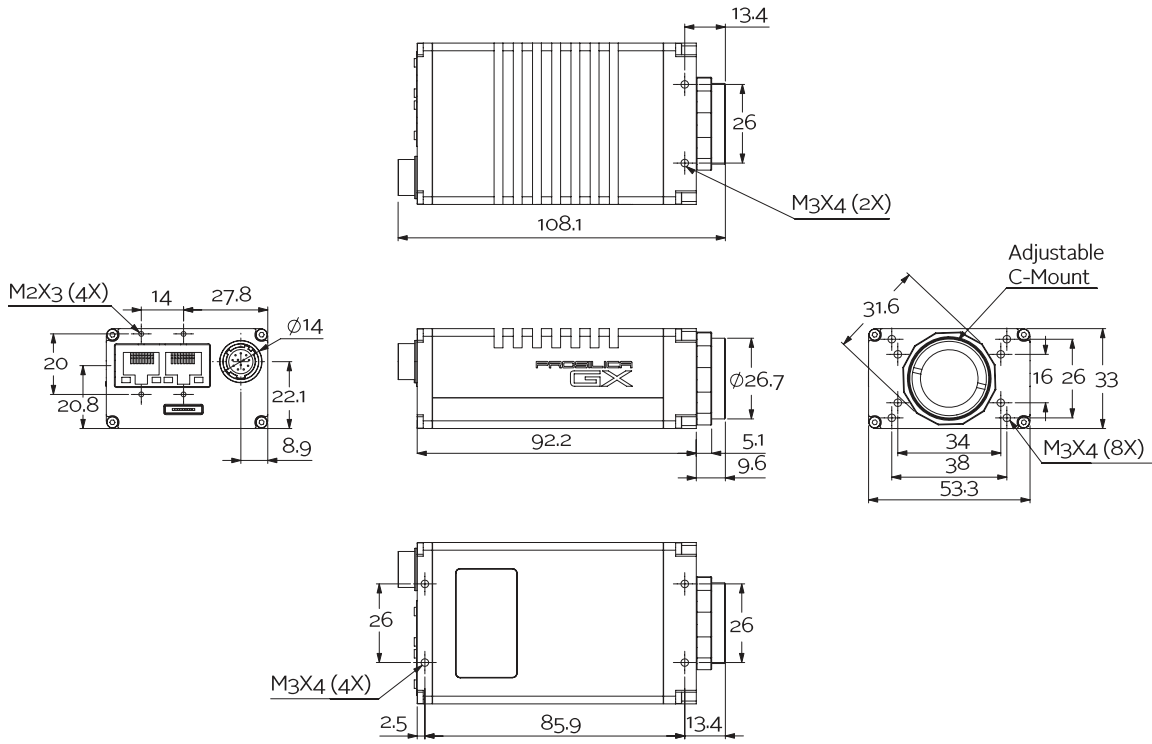



Applications

Prosilica GX1920/GX1920C is ideal for a wide range of applications including:

- Industrial inspection
- Machine vision
- LCD panel inspection
- Medical imaging
- Ophthalmology
- Aeronautical and aerospace
- Public security
- Surveillance
- Traffic imaging
- OEM applications