



Pike F-505

- Versatile IEEE 1394b camera
- Advanced feature set
- Many variants
- High frame rates

Description

5 Megapixel premium camera with numerous image pre-processing functions

The Pike F-505B/F-505C is equipped with a renowned Sony Super HAD CCD sensor and has an excellent image quality. At full resolution, it runs up to 15 frames per second. Higher frame rates can be reached by using a smaller area of interest (AOI), binning (b/w), or sub-sampling.

Options:

- IEEE 1394b connectors: 2 x copper (daisy chain) or 1 x GOF, 1 x copper, Hirose power: out
- Various IR cut/pass filters, various lens mounts
- Angled head, white medical housing

Specifications

Pike	F-505
Interface	IEEE 1394b - 800 Mb/s, 2 ports, daisy chain, fiber optic (GOF) optional
Resolution	2452 (H) × 2054 (V)
Sensor	Sony ICX625
Sensor type	CCD Progressive
Cell size	3.45 μm x 3.45 μm
Lens mount	C-Mount
Max frame rate at full resolution	15 fps
ADC	14 bit
Image buffer (RAM)	64 MByte
Output	
Bit depth	8-14 bit
Mono modes	Mono8, Mono12, Mono16

Pike	F-505
Color modes RGB	RGB8
Raw modes	Raw8, Raw12, Raw16
General purpose inputs/outputs (GPIOs)	
Opto-isolated I/Os	2 inputs, 4 outputs
RS-232	1
Operating conditions/dimensions	
Operating temperature	+5 °C to +50 °C
Power requirements (DC)	8 V to 36 V
Power consumption (@12 V)	4 W
Mass	250 g
Body dimensions (L × W × H in mm)	96.8 × 44 × 44 (including connectors)
Regulations	CE, RoHS, REACH, WEEE, FCC

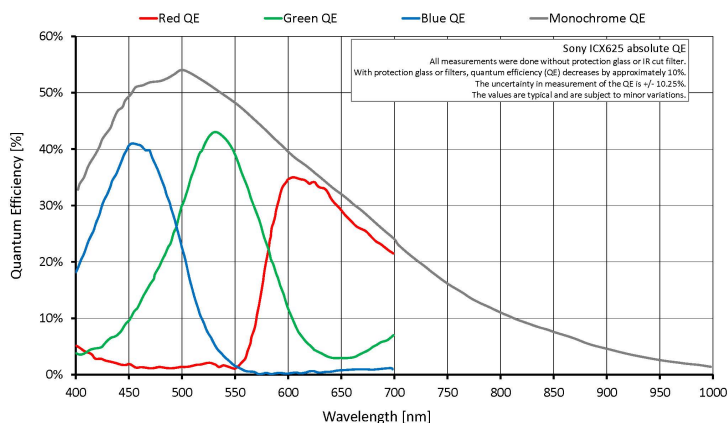

Features

- High SNR mode (up to 24 dB better signal-to-noise ratio)
- Low-noise binning mode
- Smear reduction
- Shading correction
- Area of interest (AOI), separate AOI for auto features
- Binning
- Decimation
- Auto gain (manual gain control: 0 to 24 dB)



- Auto exposure (27 μ s to 67 s)
- Auto white balance
- Look-up table (LUT)
- Hue, saturation, color correction
- Reverse X
- Deferred image transport
- Trigger programmable, level, single, bulk, programmable delay
- Sequence mode (changes the camera settings on the fly)
- SIS (secure image signature, time stamp for trigger, frame count)
- Storable user sets

Technical drawing

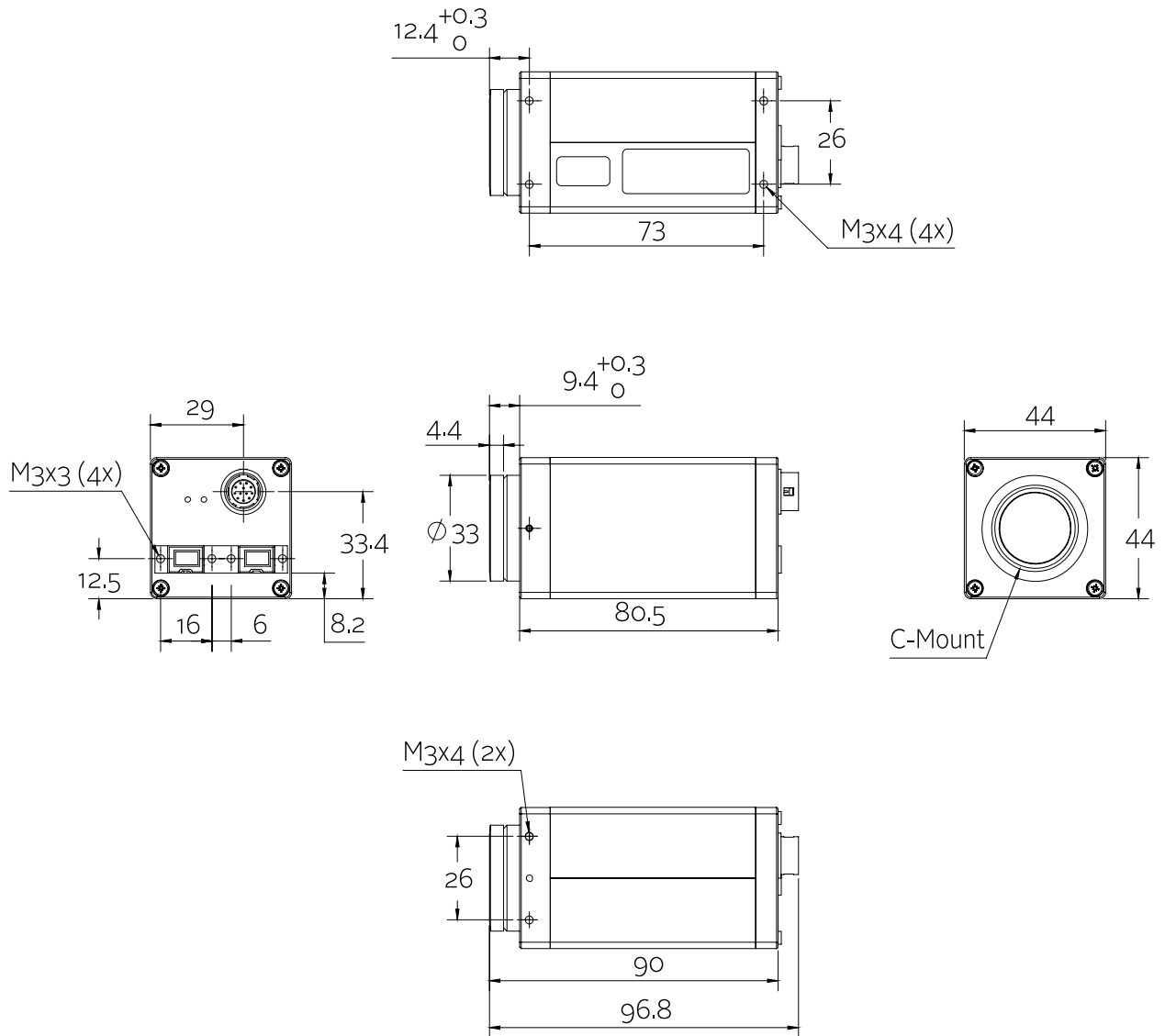



Applications

The Pike F-505B/F-505C is perfectly suited for very demanding applications. The brilliant image quality can be enhanced by its image pre-processing functions. Due to the modular design, customization is easy and cost-effective. This camera fits especially for:

- Science and research
- Microscopy
- Healthcare and medical applications (white housing available)
- Multimedia, entertainment and sports
- Very demanding OEM camera applications
- ITS (Intelligent traffic solutions)
- Long cables - 400 meters and more without additional repeaters (fiber version)