



# Guppy PRO

## F-503



- Compact 5 MP camera
- ON Semiconductor (Aptina) CMOS sensor
- Excellent price/performance
- 13 fps

## Description

Industrial CMOS camera, 5 Megapixels

The Guppy PRO F-503B/F-503C is an industrial CMOS camera with 5 Megapixel resolution. It is equipped with an ON Semiconductor (Aptina) sensor and runs 13 frames per second at full resolution.

### Options:

- Various IR cut/pass filters
- White medical housing

## Specifications

Guppy PRO	F-503
Interface	IEEE 1394b - 800 Mb/s, 1 port
Resolution	2588 (H) × 1940 (V)
Sensor	Aptina MT9P031
Sensor type	CMOS
Cell size	2.2 μm x 2.2 μm
Lens mount	C-Mount
Max frame rate at full resolution	13 fps
ADC	12 bit
Image buffer (RAM)	
	<b>Output</b>
Bit depth	8-12 bit
Mono modes	8/12/16
Raw modes	8/12/16
<b>General purpose inputs/outputs (GPIOs)</b>	

Guppy PRO	F-503
Opto-isolated I/Os	1/3
Operating conditions/dimensions	
Operating temperature	+5 °C to +45 °C
Power requirements (DC)	8 V to 36 V
Power consumption (@12 V)	<3.5 W
Mass	80 g
Body dimensions (L × W × H in mm)	44.8 × 29 × 29 (including connectors)
Regulations	CE, RoHS, REACH, WEEE, FCC

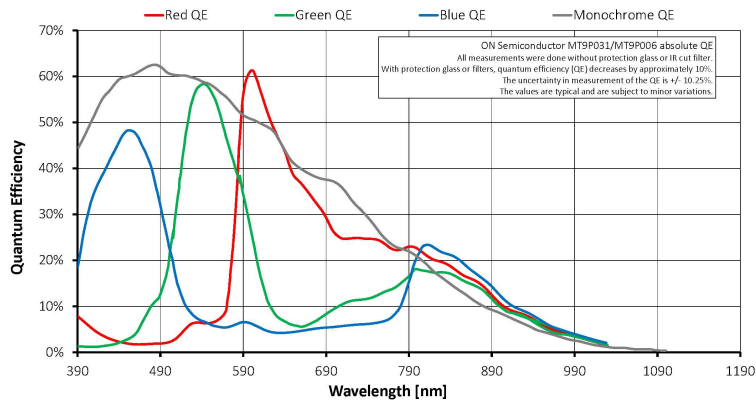

## Features

- Look-up table (LUT)
- Gamma correction
- Color correction
- Defect pixel correction
- Area of interest (AOI), separate AOI for auto features
- Binning (monochrome and color)
- Low-noise binning
- Sub-sampling
- Image mirror H+V (color version only horizontal)
- Auto gain (manual gain control: 0 to 18.06 dB)
- Auto exposure (20  $\mu$ s to 22.3 s)
- Trigger with edge mode and programmable delay

- Storable user sets

## Technical drawing

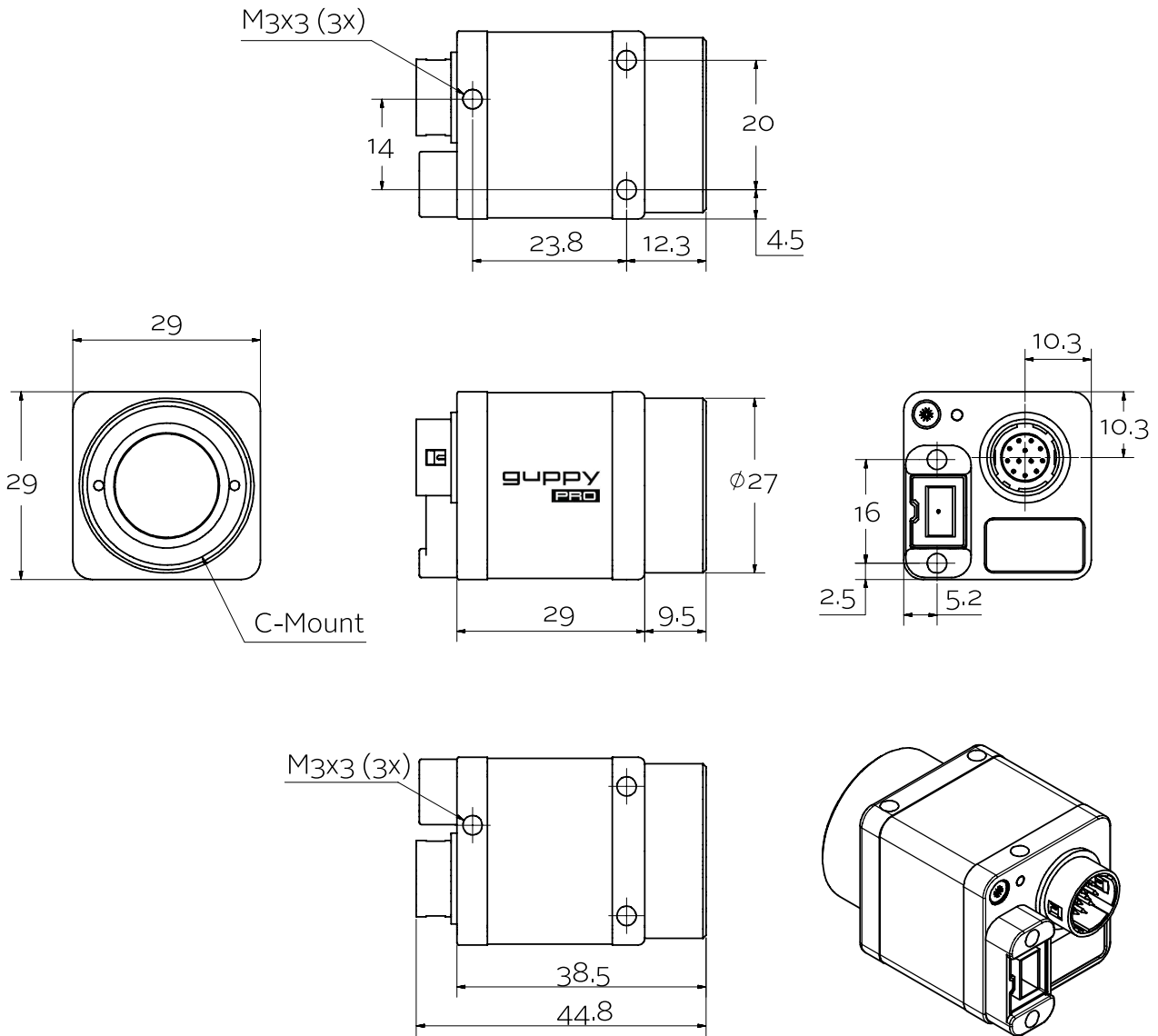



## Applications

Thanks to the CMOS sensor and 5 Megapixel resolution, the Guppy PRO F-503B/F-503C is an industrial CMOS camera with a high performance and a very attractive price.

Applications:

- Industrial inspection with high resolution
- Robotics
- Logistics
- Pharmaceutical industry
- Multimedia
- ITS/Traffic monitoring